



CSI Mk 2

CONTOUR SAND INJECTION VERTICUTTER / SCARIFIER



Owner's Manual

GRADEN TURF MACHINERY

Manufactured under licence by

Turf Machinery

1 Waitchie Street

Wedderburn 3518

Victoria Australia

Tel - (03) 5494 3059

Web - gradenturfmachinery.com

Email - turf.engineering@bigpond.com

Contact - Geoff Burnside

Table of Contents

1. Specifications

- 1.1 Specifications
- 1.2 Statement of Machine Use
- 1.3 Serial Number Plate

2. To the Owner

- 2.1 Preliminary Instructions
- 2.2 Warning Symbols
- 2.3 Servicing the Verticutter

3. Safety Information

- 3.1 General rules
- 3.2 Training
- 3.3 Personal Protective Equipment (PPE)
- 3.4 Preparation
- 3.5 Operational Safety
- 3.6 Maintenance Safety
- 3.7 Transport Safety

4. Controls

- 4.1 Motion Control Handles
- 4.2 Reverse Lever
- 4.3 Blade Engage Handle
- 4.4 Lifting/Lowering Controls
- 4.5 Throttle Lever
- 4.6 Choke Lever
- 4.7 Ignition Switch
- 4.8 Neutral Lever
- 4.9 Cutting Depth Control
- 4.10 Speed Gauge
- 4.11 Sand Flow Metering Gauge
- 4.12 Safety Interlocks

5. Operating Instructions

- 5.1 Preliminary Checks
- 5.2 Start Up
- 5.3 Driving (traversing) the Verticutter
- 5.4 Verticutting
- 5.5 Sand Injection Verticutting
- 5.6 Shut Down
- 5.7 Clean Down

Table of Contents (cont'd)

6. Maintenance Operations

- 6.1 Adjustments and Settings
 - 6.1.1 Injection Tube Adjustment
 - 6.1.2 Rotor Relay Belts
 - 6.1.3 Rotor Belts
 - 6.1.4 Gearbox Drive Belt
 - 6.1.5 Transmission Drive Belt
 - 6.1.6 Auger Drive Belt
- 6.2 Replacements
 - 6.2.1 Blade Replacement
 - 6.2.2 Belt Replacement
 - 6.2.2.1 Rotor Belts
 - 6.2.2.2 Rotor Relay Belts
 - 6.2.2.3 Gearbox Drive Belt
 - 6.2.2.4 Transmission Drive Belt
 - 6.2.2.5 Auger Drive Belt
- 6.3 Engine Maintenance
- 6.4 Battery Maintenance
- 6.5 Maintenance Schedule

7. Parts Diagrams

8. Wiring Diagram

9. Warning/Compliance Decals

1.1 Specifications

Model	CSI Mk2 - Contour Sand Injection Verticutter/Scarifier
Engine	Honda GX630
Power	15.5kW(20.8HP) Horizontal shaft
Engine Oil	SAE 10W-30 Grade Approx. 1.5 litres (without oil filter replacement) Approx. 1.7 litres (with oil filter replacement)
Fuel	Unleaded
Cutting Width	515mm
Cutting Depth	0-40mm (maximum with standard blades)
Blades	Tungsten carbide tipped spring steel
Blade Size	
Part Number 0232	210mm Diameter – 2mm tip (Standard)
Part Number 1122	210mm Diameter – 1mm tip (Optional)
Part Number 0217	210mm Diameter - 3mm tip (Optional)
Blade Tip Speed	2,375m/min at 3600 rpm
Blade Configuration	17 Blades at 32mm spacings
Weight	290kgs
Length x Width x Height	130cm x 103cm x 123cm
Tyres	
Front	16 x 6.50 – 8 Turf Pattern - tubeless
Rear	9 x 3.50 – 4 Slick Pattern – tube type
Tyre Pressure	
Front	69 kPa (10 psi) - maximum
Rear	103 kPa (15 psi) – maximum
Rotor Belts	Carlisle B32 Super II V-Belt
Rotor Relay Belts	Carlisle B38 Super II V-Belt
Gearbox Drive Belt	Carlisle A31 Super II V-Belt
Transmission Drive Belt	Carlisle A31 Super II V-Belt
Auger Drive Belt	Carlisle A24 Super II V-Belt

1.2 Statement of Machine Use

The Graden Contour Sand Injection Verticutter/Scarifier's main use is as a verticutting/scarifying/de-thatching tool with the option to inject sand into the newly created grooves on areas such as golf courses, bowling greens, cricket wickets, tennis courts and other sporting fields and fine turf areas.

It is not for use on turf areas where rocks and other hard foreign bodies may be present. The use of this machine in turf profiles of this nature will likely cause premature wear or shattering of the blade tips and could result in rocks being projected at dangerous speeds, resulting in potential injury to the operator or damage to the machinery.

This machine is not for use in anything other than the soil profiles typically to be found on the sporting fields mentioned above. Any use of this machine in any other type of surface or for any other purpose may void the warranty.

Please contact Graden Industries if you are unsure about your application complying with the intended use of this machine.

1.3 Serial Number Plate

The serial number plate layout is shown below. It is important to note in particular the Model and Serial numbers to assist you when ordering parts or discussing servicing needs with your Graden Dealer. Also on the plate you will find mass information and the year of manufacture.

GRADEN	
INDUSTRIES PTY LTD	
26 - 28 SCAMMEL STREET	
CAMPBELLFIELD VICTORIA 3061	
MADE IN AUSTRALIA	
MODEL N ^o _____	MASS _____
SERIAL N ^o _____	YEAR _____

2. To the Owner

Read this manual before operating the Verticutter

2.1 Preliminary Instructions

- It is important that the owner completely familiarises themselves with the contents of this manual
- Keep this manual at hand as a ready reference for anybody using the Graden Contour Sand Injection Verticutter
- The designed and tested safety features of this machine are dependent on it being operated within the limitations described in this manual

2.2 Warning Symbols

Throughout this manual the following safety alert symbols are used to indicate important safety issues. When either of these symbols are present the operator must be aware that there is the potential to damage equipment and/or incur serious personal injury.

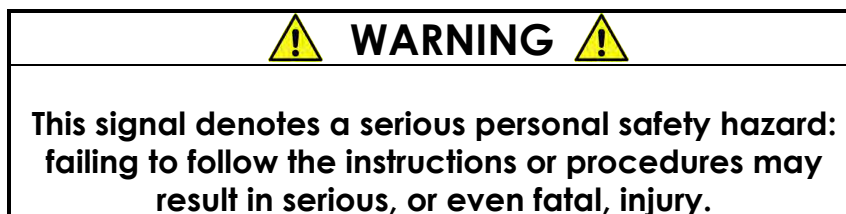
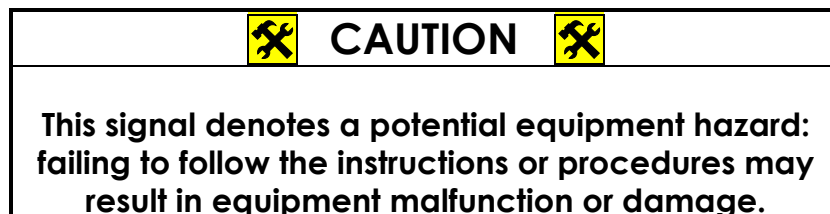

2.3 Servicing the Graden Contour Sand Injection Verticutter

The Graden Contour Sand Injection Verticutter has been carefully engineered and manufactured to provide safe, dependable and effective service.

As with all mechanical equipment it requires routine cleaning and maintenance.

Your authorised Graden representative has access to tools, genuine spares and equipment to service any and all of your requirements.

Use only genuine Graden parts; substitute parts will void the warranty and may not meet the safety and performance standards required for safe and effective operation of the Verticutter.

Please record the model and serial numbers of the Verticutter in the space provided below and quote this information when ordering parts or communicating with Graden Industries or its' approved representatives.

Model :	CSI Mk2
Serial Number :	_____
Date Purchased :	_____

3. Safety Information

This manual is provided to help you operate and maintain the Contour Sand Injection Verticutter. Please read it carefully.

It has been compiled from extensive field experience and engineering data.

In some aspects it is generalised because it is impossible to cover all operating scenarios. However, combining the information provided in this manual with your own increasing experience and knowledge with the Contour Sand Injection Verticutter will enable you to develop procedures suitable for your individual needs.

This machine, like most modern machinery, is constantly undergoing development on the basis of experience and market needs. At the time of printing, material in this manual was current but may vary due to the aforementioned ongoing development.

Graden Industries reserve the right to change the machinery specifications without notice.

3.1 General Rules

- Direction on the machine (right or left) is determined from standing behind the handles and facing in the direction of forward travel
- Numbers in brackets are listed in this manual; they refer to the part numbers shown on the diagrams and are listed to assist in part identification
- When viewed from the right side the blades rotate anti-clockwise (counter rotating to the forward rotation of the front drive wheels)
- This is a precision piece of machinery with high speed cutting blades



- Do not allow children to operate the machine or be near it during its' operation
- Only people who are very familiar with the rules of safe operation should be allowed to use this machine

- Only use the machine during daylight or in good artificial light
- Some illustrations in this manual may show the Verticutter with safety guards removed, this is not a normal situation!



3.2 Training

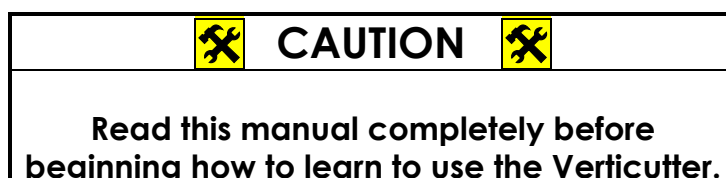

- Do not allow anybody to operate the machine without instruction
- Know your controls and how to stop the machine and shut down the engine quickly in an emergency
- To maintain control and reduce the possibility of upset, damage or collision, operate the machine smoothly. Avoid erratic operation and excessive speed

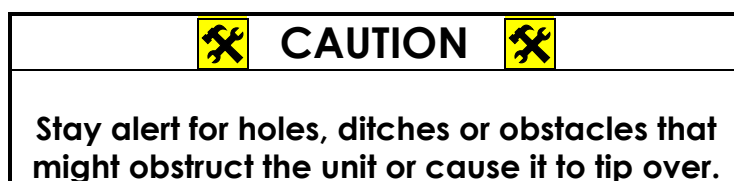

- Be aware of the hazards associated with the engine :
 - ⇒ Petrol is highly flammable so only use an appropriate container
 - ⇒ Never remove the fuel cap or add fuel while the engine is running or still hot
 - ⇒ Never add fuel indoors and wipe up any spillages
 - ⇒ Never run the engine in an enclosed area because exhaust gases are toxic

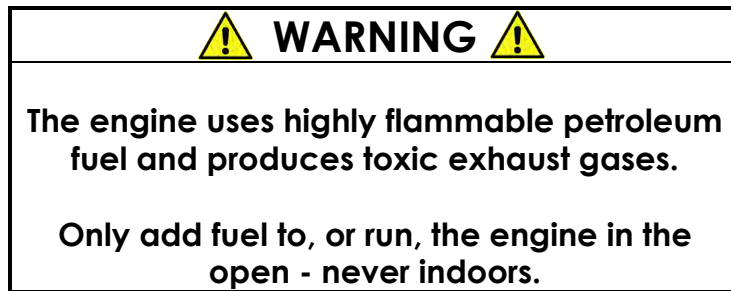

3.3 Personal Protective Equipment (PPE)

- Clothing should be reasonably snug fitting and not free flowing so as to avoid the risk of entanglement in moving parts
- Wear sturdy footwear, preferably steel capped safety shoes or boots
- Use appropriate PPE for eyes, ears and hands





3.4 Preparation

- Ensure all safety warnings and decals are in place and legible
- Remove any accumulated debris that might represent a fire hazard
- Ensure that the blades are in a serviceable condition and that the rotor shaft mounting bolts are secure
- Perform any appropriate scheduled maintenance before starting the machine

3.5 Operational Safety



- Always disengage the rotor blades before attempting to start the Verticutter
- Always raise the rotor blades before attempting to start the machine

- Always disengage the blades and raise them when crossing gravel, walkways, roads, etc. or indeed any ground which you do not wish to verticut

 WARNING 
<p>Always disengage the rotor blades and stop the engine in <u>any</u> of the following situations :</p> <ul style="list-style-type: none">• leaving the machine unattended• attempting to unclog or clear the blades• making any repairs or adjustments• inspecting the unit for damage after striking any foreign object

- Always repair any damage before recommencing operation

3.6 Maintenance Safety

 WARNING 
<p>Raise blades clear of turf, disengage blades and turn off engine before carrying out any maintenance or servicing.</p>

- Never allow anybody to start the engine while adjustments, maintenance or servicing are being performed
- Keep machine free of any debris
- Remove debris from underneath the Verticutter after each use
- Verify that all warning labels and decals are present, visible and legible
- Periodically check that all bolts, fasteners and catches are secure and in safe operating condition
- After any maintenance or servicing, ensure that all guards and safety devices are correctly installed and secure before operating the Verticutter



WARNING



Frequently check the rotor blades. Verify that all the tips are in good condition.

Ensure that the blades are firmly held and there is no slack due to damaged or worn spacers.

3.7 Transport Safety

When transporting the unit it is very important to;

- Always ensure the blades have been disengaged and the rotor housing raised before loading or unloading the machine onto/from a trailer or other transportation device.
- Ensure the engine has been turned off at the ignition switch.
- Ensure the machine is securely tied down during transport.



CAUTION



Ensure the blades have been disengaged and the rotor housing lifted into the raised position before loading or unloading the unit onto a trailer, or serious damage to equipment could occur.

4. Controls

Please refer to the illustrations. All directions are given with reference to standing behind the handles and facing in the direction of forward travel.

4.1 Motion Control Handles

These handles (1639) control forward motion of the Verticutter, as well as allowing you to steer the machine left and right.

They naturally return to the neutral position when released. To move forward, rest your hands on top of the controls and gently push down. The further down they are pushed, the faster the forward speed of the machine.

Maximum forward speed corresponds to a brisk walking pace.

To go in reverse see instructions under REVERSE LEVER. The Motion Control Handles are fitted with a Safety Switch (5602) in the top of the handle. Whilst the blades are engaged one or both of these buttons must be depressed at all times or the engine will switch itself off.

4.2 Reverse Lever

The reverse lever (1211) allows you to reverse the machine, it is speed limited for safety reasons. Before reversing always ensure you have a clear path to reverse over and there is plenty of room to manoeuvre the machine. Reverse is engaged by sliding the lever to the right and pulling back towards yourself. When you are finished reversing, release the lever and it will automatically return to the neutral position.

It is important to NEVER reverse up to a wall, fence or other obstacle. Always ensure you have adequate room to reverse the machine where you want and still allow plenty of room for yourself to manoeuvre. Release the handles to let the machine return to the neutral position.

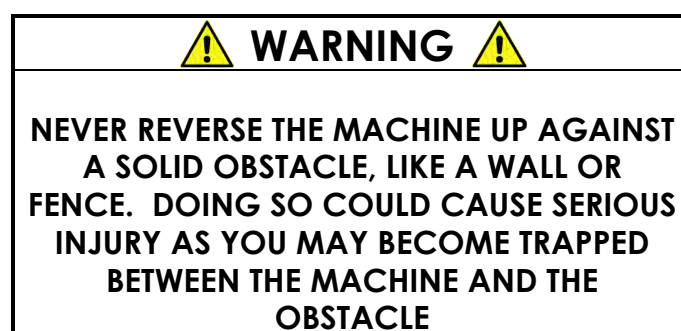

4.3 Blade Engage Handle

This handle engages the rotor blades.

Pull the blade engage handle (1485) towards you gently and smoothly until it locks down in position against the control panel. The blades are now engaged. Push the blade engage handle away from you to disengage the blades.

4.4 Lifting/Lowering Controls

The Lifting/Lowering Handle lowers and raises the blade housing.

The blades should be engaged before lowering them into the turf to avoid undue stress to the rotor belts and engine.

To operate just push this lever forward to lower the blade housing into the turf.

This should be done gently to allow the blades to 'dig' their way into the turf.

To raise the rotor housing, pull the lever back towards the operator, coming right over until it is resting against the control panel.

CONTROL PANEL CONTROLS

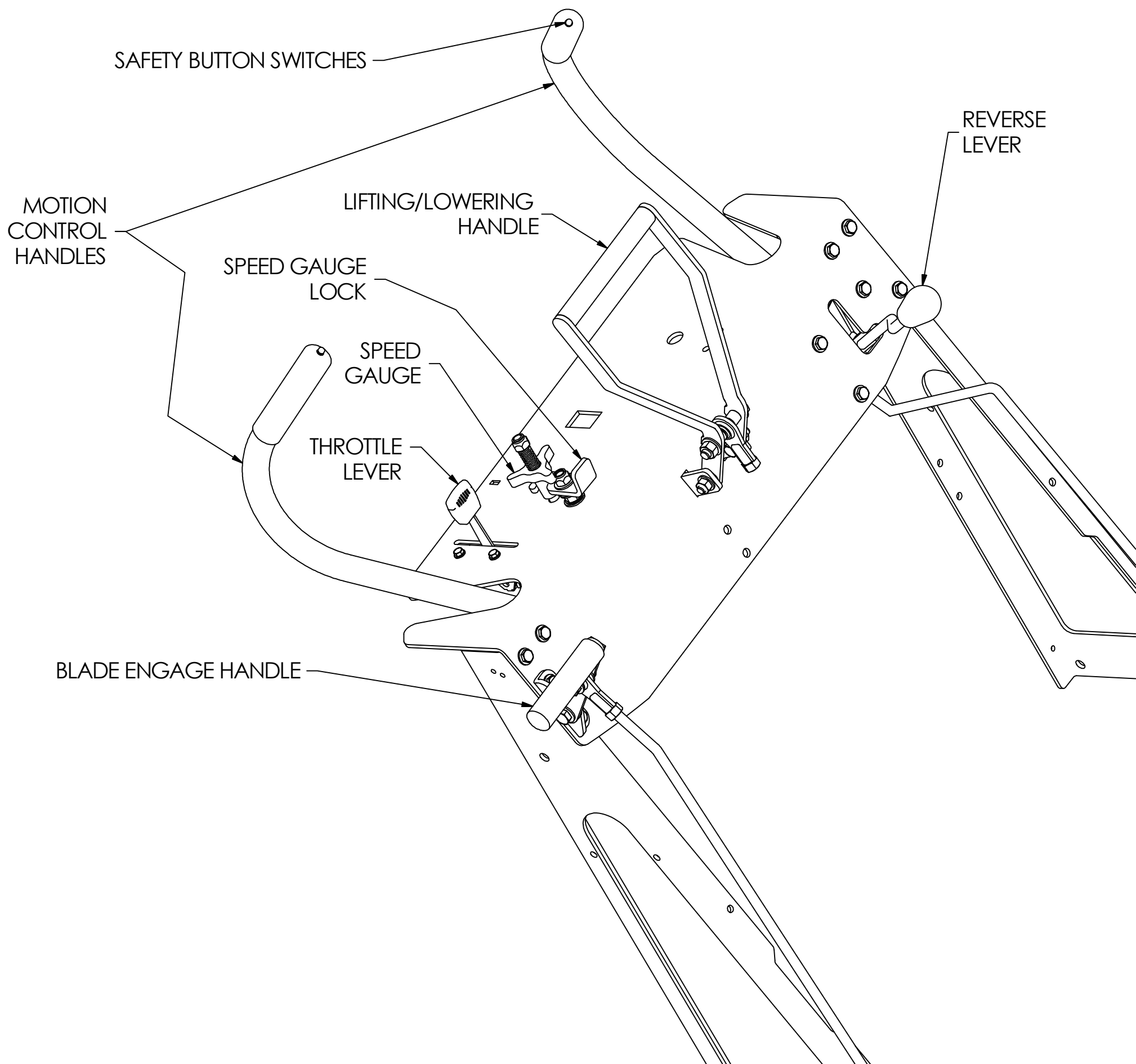

4.5 Throttle Lever

Controls rpm of the engine.

Moving the lever upwards decreases the engine speed. Moving it downwards increases engine speed. All the way up is the engine idle position. Verticutting should be carried out at a high engine speed to give high tip speed and a better cut. When you are finished using the machine, the engine should be run at idle for a few seconds before shutting the engine down.

4.6 Choke Lever

This control is required when starting the engine.

Before turning the ignition switch, pull the Choke control to on. Set the throttle lever as described below, then use the Ignition Switch to start the machine as described below. Once the engine is running, push the Choke control to off. Do not use the choke if the engine is already warmed up or the air temperature is high.

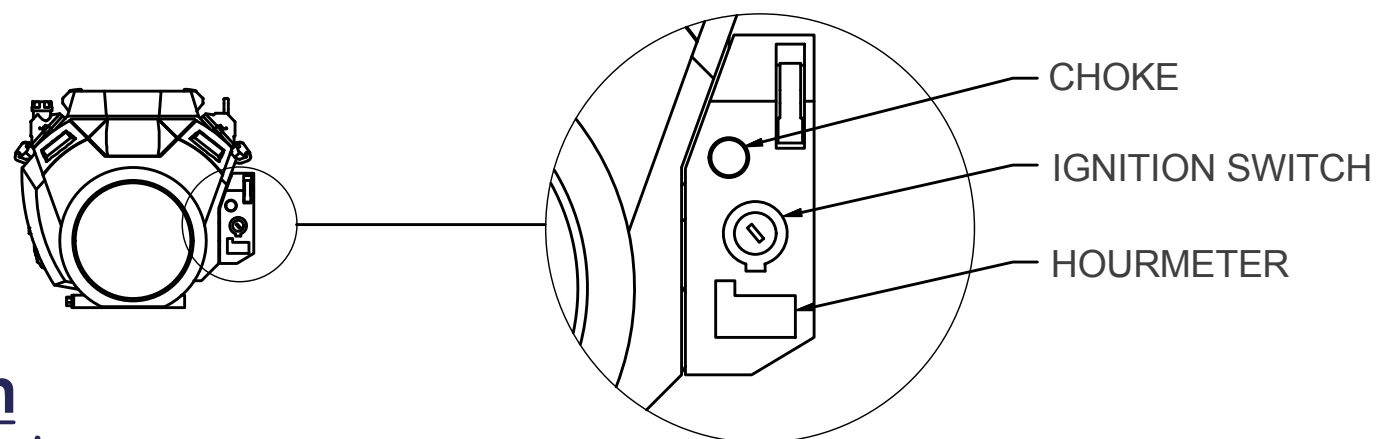

4.7 Ignition Switch

Starts and stops the engine.

This key switch is located on the control panel of the engine. It has three positions; OFF, ON and START. To start the machine, first make sure the choke control is on and the throttle control is set slightly towards the FAST position. Now turn the key to the START position until the engine fires. Release the key and it will automatically return to the RUN position. Move the Choke to off and set the throttle to the desired speed. When you have finished using the machine, move the throttle lever down to the idle (SLOW) position and let the machine run for a few seconds, then turn the key to OFF.

4.8 Neutral Lever

This small lever (2150) is located on the left side of the machine, behind the front drive wheel, and has two positions;

NEUTRAL: allows the machine to be pushed manually

DRIVE: engages the transmission for normal operation

The neutral lever is a small lever which requires the operator to pull the lever out through the keyhole to put the machine in the drive position. Neutral is obtained by pushing the lever back through the keyhole on the machine.

4.9 Cutting Depth Control

The cutting depth is set via the height adjustment thread (1486) located on the left hand side of the unit on the rotor housing assembly. The depth is adjusted by screwing the control in or out. The control has a locking lever (1464) to hold it in place to maintain the cutting depth whilst cutting.

4.10 Speed Gauge

When using the sand injection feature of the machine the speed control adjuster (1489), located on the control panel, will need to be used to maintain a constant forward speed to ensure even sand distribution. The adjuster can be screwed in or out to adjust the speed, then the speed gauge bracket (1463) must be turned around to lock the forward speed until you have finished your pass. To give you full speed again you need to turn the speed gauge bracket back out of the way.

4.11 Sand Flow Metering Gauge

This small gauge (2604) located just above the left rear tyre on top of the Carriage Bracket (1299) sets the flow rate of the sand from the hopper (1274). There are three discrete positions; LIGHT, MEDIUM and HEAVY. LIGHT is the first position and allows the least amount of sand through. MEDIUM is the next position and allows a medium flow rate of the sand. HEAVY is when the gauge is turned so the bracket allows full flow of sand through to the injection tubes. These three positions are shown in the diagram below. The Sand Flow Metering Gauge is used in conjunction with the forward Speed Gauge control to get the sand into the groove at the desired level.

SAND FLOW METERING GAUGE SETTINGS

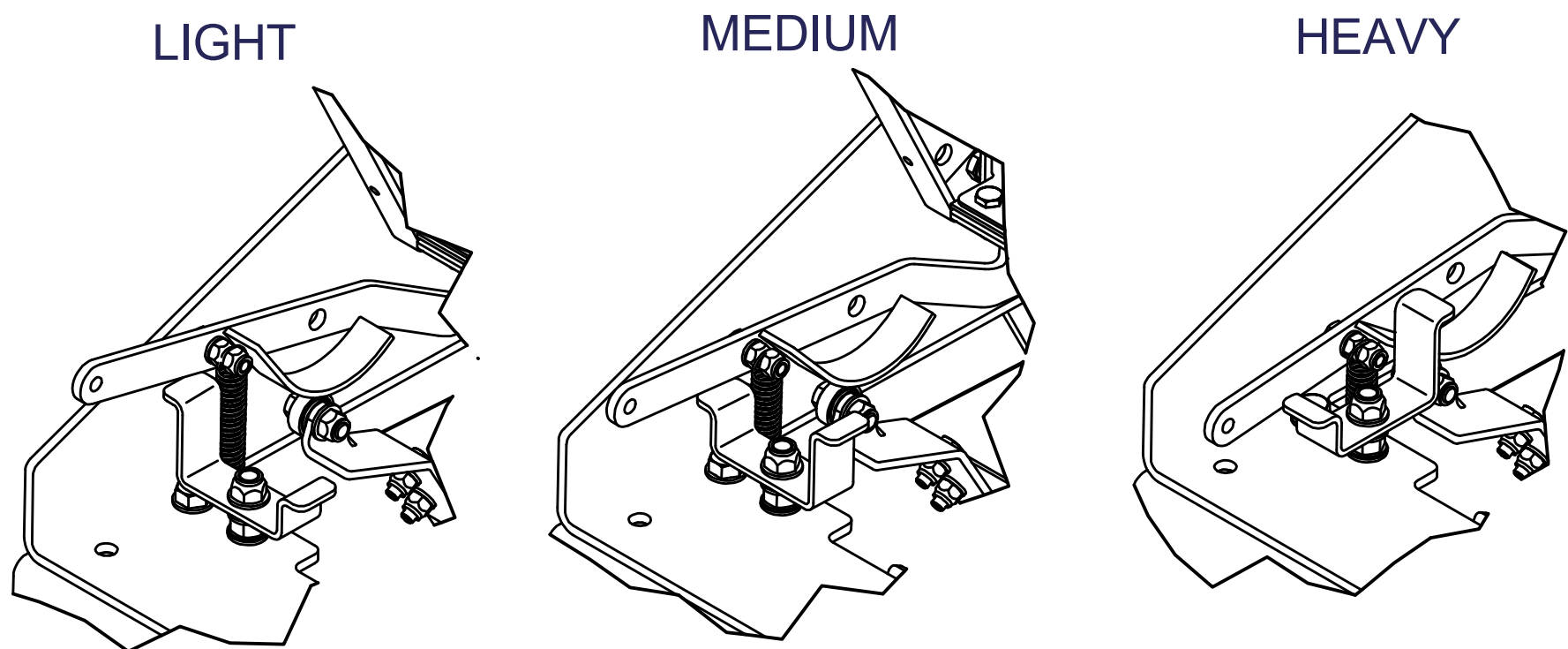

4.12 Safety Interlocks

This machine is fitted with a couple of safety interlock switches to protect the operator from harm. As mentioned under the MOTION CONTROL HANDLES section, there are two small button switches in the ends of the Motion Control Handles, which are linked to a safety switch on the blade engagement system. Before and during blade engagement one or both of these small button switches must be pressed down and held down. If the operator releases both buttons whilst the blades are engaged the engine will cut out for the operators safety. There is also a safety switch connected to the blade engagement lever to make sure you cannot start the machine with the blades engaged.

5. Operating Instructions

 **WARNING** 

Do not operate the Verticutter until you have completely read this manual.

5.1 Preliminary Checks

1. Clear any debris from above and underneath the machine
2. Ensure scheduled maintenance activities have been completed.
3. Inspect belts for condition and correct tension.
4. Inspect blades for wear or damage.
5. Ensure all guards and covers are firmly fixed in place
6. Check engine oil level; change according to manufacturer's recommendations.
7. Ensure there is petrol in the fuel tank.

5.2 Start Up

1. Check that blades are disengaged - push blade engage handle all the way forward.
2. Check that blades are in raised position - pull lift/lower handle towards you and ensure that it locks into position
3. Put neutral lever (left side of machine) into the NEUTRAL position (lever pushed into the base).
4. Engage the choke lever, set the throttle lever.
5. Turn ignition switch around to the START position. Release key when engine starts. Key will return to the RUN position automatically.
6. Push the choke lever in.
7. From the operating position, move the throttle lever to the desired setting.

 **WARNING** 

It is advisable to practice driving the machine in a wide open area when first learning. This will allow you to get comfortable with the controls and how to stop the unit quickly.

5.3 Driving (Traversing) the Verticutter

1. Put the neutral lever (left side of machine) to the DRIVE position (lever pulled out of the base).
2. Use the motion control handles to move in the desired direction. Push the handle downwards to move forward; to reverse use the reverse lever. Maximum reverse speed is considerably slower than maximum forward speed.
3. Speed is controlled by the pressure applied to the motion control handles. The further the handles are pushed down, the faster the forward speed.
4. To turn push the handles left or right. If you do this at high speed you may lose control of the unit. So until you are familiar with the controls and the 'feel' of the machine, it is important that you reduce your speed when starting a turn, just like you would when driving a car around a corner. If you feel the unit is 'getting away' from you then release the levers so they will return to the neutral position automatically and the machine will come to a stop quickly.

5.4 Verticutting

1. Select the depth of cut via the height adjustment knob on the left hand side of the rotor housing. Normal range of cut (with standard 210mm blades) is 0mm to 40 mm deep. One revolution of the knob is approximately equivalent to 1mm change in the cutting depth. Clockwise rotation of the knob means a shallower cut; anti-clockwise means a deeper cut. It is recommended to do a test run if you are unsure of the cutting depth. Measure it and adjust the setting accordingly.
2. Increase engine speed to maximum rpm; maximum engine speed results in a high blade tip speed and a cleaner cut.
3. Engage the blades by slowly pulling the blade engagement handle toward you. It will lock in the engagement position.
4. Lower the blades into the turf by slowly pushing the lifting/lowering lever forward. Allow the weight of the Rotor Housing to take the blades into the turf.
5. Now push down on the Motion Handles until you are travelling at the desired speed.
6. Steer the machine in a straight line while the blades are cutting. Trying to change direction while the blades are in the turf may lead to a furrowing/scalping action and can put undue stress on the belts, blades and machine in general.
7. At the end of a pass;
 - raise the blades by pulling the lift/lower lever towards you
 - steer the Verticutter around to make your next run
 - repeat from Step 4 onwards

For extra safety, disengage the blades before lifting them out of the ground. This will stop the blades rotating quicker. When travelling from area to area disengage the blades and raise them.

5.5 Sand Injection Verticutting

1. If you wish to sand inject whilst Verticutting, you will need to fill the hopper with kiln-dried sand before starting the pass. It is advisable not to attempt to sand inject in wet weather, as even the smallest amount of rain will make the dried sand block up the injection tubes, resulting in uneven and inconsistent sand levels in the grooves.
2. You will need to experiment to get your cutting depth, speed gauge setting and sand flow adjuster setting in synchronization with each other. The ideal result is that the grooves are filling to the top with sand, not being left shallow or heaping over the top of the groove.
3. Once you have the setting right for your depth of cut, it is a good idea to note the settings you have for future reference. A set of guidelines has been drawn up in the table below. They are only guidelines and you may find in your own circumstances that you need to adjust the settings for your conditions and preferences.

Cutting Depth (mm)	Cutting Depth (inches)	Sand Flow Adjuster	Speed Limiter Setting
6	¼"	LIGHT	Very High
10	3/8"	LIGHT	High
13	½"	MEDIUM	Medium-High
20	¾"	MEDIUM	Medium
25	1"	MEDIUM-HEAVY	Medium-Low
30*	1 ¼"	HEAVY	Low to Medium*
35*	1 3/8"	HEAVY	Very Low to Medium*

* At these deeper settings, you will find that as the machine continues along the pass, the accumulated debris being removed by the blades actually starts slowing the machine down, so it will probably be necessary for you to adjust the Speed Limiter during the pass to increase your forward speed. This will avoid sand heaping up out of the groove due to the slowing down of the machine.

4. As you engage the blades for your pass, the distributor tray for the sand will automatically open and the sand will start pouring into the grooves. You should immediately pull the levers down to the speed limit you have set to ensure consistent depth.
5. When you reach the end of your pass immediately raise the rotor housing and the sand will be automatically shut off.
6. Check the sand level in the hopper after every pass and top up as required. On long passes you may need to top up the sand on the go, as it is important to never run out of sand.
7. Line up the machine for the next pass and repeat from step 4 onwards until you have completed your job.

5.6 Shut Down

1. Disengage blades.
2. Raise blades out of turf.
3. Traverse machine to storage/maintenance area.
4. Turn engine speed to idle, allow to run for 10 seconds.
5. Turn ignition switch to OFF.
6. Clear rotor blades of any debris.
7. Check transmission, ensuring it is cleaned of all dirt and debris that may hinder cooling.
8. Generally clean the Verticutter, making sure that there is no accumulated debris, particularly around the engine.
9. The hopper should be emptied and thoroughly cleaned after use.

5.7 Clean Down

1. Remove all grass clippings, sand and dirt and other debris from the outside of the machine, this is best done by hand or with an air hose.
2. Raise the rotor housing and lift the back of the machine to access the inside of the rotor housing, then remove all accumulated debris underneath the housing, from the blades, the auger and the injection tubes.
3. Check around the transmission for any build up of dirt and remove immediately, to avoid overheating of the transmission due to inefficient cooling.

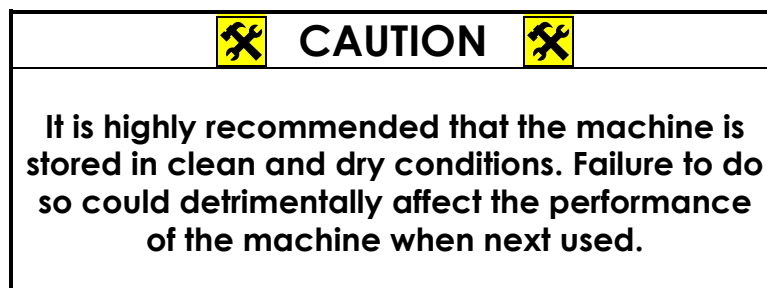
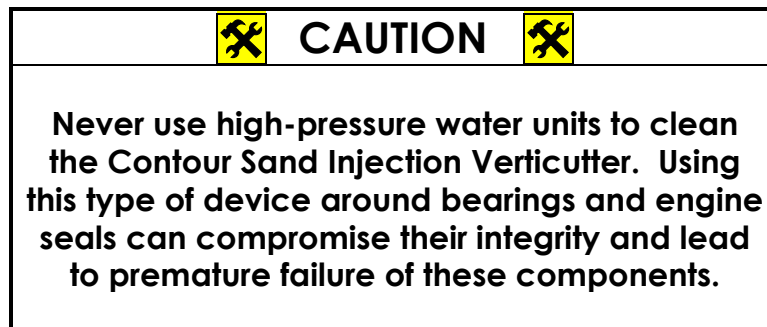

6. Maintenance Operations

The performance of certain maintenance, adjustment or repair operations will be determined by the owner's facilities.

Tilting of the machine for the purpose of under-deck servicing should be avoided.

If the Verticutter is tilted forward (i.e pivoting over the front axle) there is a risk that engine oil can enter the cylinder head of the engine. This can result in expensive repairs so it is not recommended unless absolutely necessary.



For the purpose of under-deck servicing, it is recommended that the machine be lifted on a joist or small crane or the entire rotor housing box be removed from the main chassis of the machine.

6.1 Adjustments and Settings

6.1.1 Injection Tube Adjustment

The injection tube depth is vital to the correct operation of the sand injection machine. It is set at the factory for optimum performance, but it may be possible that you will find the need to raise the tubes further out of the ground or drop them further down to help improve sand injection performance. To do this some adjustment has been provided via two depth adjusting screws that the tray mounting bracket rests on. By screwing these screws further out or in, the depth of the tubes into the ground is adjusted. These screws are located underneath the hopper. See the diagram on the following page for their location. To adjust them you must first release the locking nut holding the screw firm, then screw the bolt in or out to change the depth setting. When you are happy with the depth setting, re-tighten the locking nut. Both screws must be adjusted together.

There is also adjustment to allow movement of the distributor tray either left or right to correct any misalignment of the injection tubes with the blade grooves. If you find that the injection tubes do not seem to be lining up perfectly with the blades, then you can adjust the tubes by releasing the four mounting nuts on the distributor tray bracket, which should allow you to move the distributor tray and sand injection tubes into line with the blades, then re-tighten the four mounting nuts back in place.

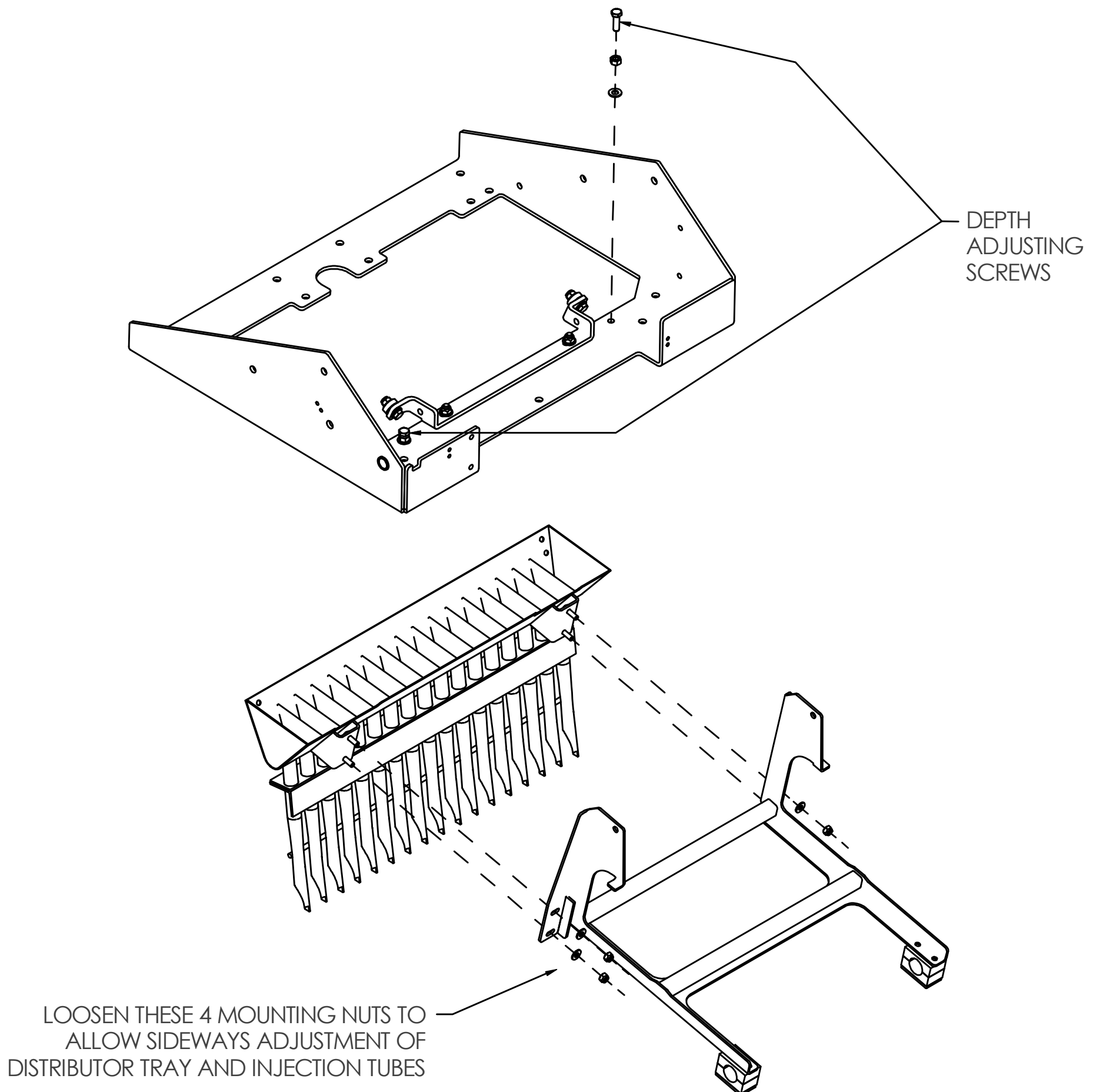

6.1.2 Rotor Relay Belts

Correct tension on the rotor relay belts (5342) is assured by the spring bracket mechanism on the Blade engagement lever. This mechanism provides correct tension to the rotor relay belts. As the belts stretch, if further tension is required, the nut on the end of the clutch rod (1343) can be tightened to increase the tension on the belts.

6.1.3 Rotor Belts

These two belts (5325) are under the rotor belt cover. They are tensioned via an idler pulley mounted to an idler arm, which can be adjusted without removing the cover. Loosen the locking nut on the idler adjuster (0424) and then tighten the adjusting nut until sufficient tension has been achieved. Re-tighten the locking nut.

6.1.4 Gearbox Drive Belt

This belt (5709) is accessible under the main cover (2775) and inside the engine base. Once the main cover has been removed, the belt can be tensioned up by loosening the idler pulley bolt and sliding the idler pulley (0610) further forward in its mounting slot, then re-tightening the bolt.

NOTE: To get easier access to this pulley you can unbolt the fuel tank from the front of the machine and carefully move the tank onto the top of the engine base (ensuring the fuel lines are not stretched).

6.1.5 Transmission Drive Belt

This belt (5709) is accessible under the engine base (2776). To tension up the belt you must slide the idler pulley (0610) further backward in its mounting slot. To access the idler pulley bolt, first raise the back tyres on a couple of bricks or timbers then lower the rotor housing as far as you can which will give you access to the bottom of the idler pulley. Then loosen the idler pulley bolt, slide the pulley back in the slot and re-tighten the bolt.

6.1.6 Auger Drive Belt

The auger drive belt (5423) is under the auger cover (1353) on the left hand side of the rotor housing. Once the cover has been removed, the belt can be tensioned up by loosening the idler pulley bolt and sliding the idler pulley further up in its mounting slot, then re-tightening the bolt.

6.2 Replacements

6.2.1 Blade replacement

1. Remove the Pivot Wheel Arms (1052 & 1761) from the machine.
2. Remove the rotor belt guard (1168).
3. Remove the auger cover (1353) on the left hand side.
4. Take all tension off the rotor belts (5325) by loosening off the idler pulley (5314).
5. Take tension off the auger belt by loosening the idler pulley (0610), then remove the auger drive belt (5423) from the pulley (9370) on the rotor shaft.
6. Remove rotor belts (5325) by easing them off the pulley (5316) on the end of the rotor shaft (1338).
7. Remove the sand injection tubes (1372) by unbolting them from the distributor tray (1373). This will allow the blade reel to be removed from the rotor housing (1281).

8. Undo the bolts holding the bearings (5319) at each end of the blade reel.
9. Undo the grub screws holding the left hand bearing (the auger belt end) to the shaft and allow the left bearing to slide along the rotor shaft to provide some free movement, then gently allow the blade reel to drop free from the machine. Take care to perform this operation with a protective layer under the machine (old carpet is ideal) to protect the blade tips from being dropped onto a hard surface.
10. Lift the rotor housing clear of the blade reel, then pull the reel clear of the machine.
11. Remove the pulley (9370) from the left end of the blade reel.
12. Slide the left end bearing from the end of the rotor shaft.
13. Remove the left Nyloc nut (5089) and rotor shaft washer (0039) from the rotor shaft.
14. Remove blades and spacers from the shaft.
15. Replace blades and spacers as required, ensuring that they go back on the shaft in the same direction and configuration (i.e. counter rotating to direction of forward travel and successive blades offset one face on the rotor shaft).
16. Re-fit the rotor shaft washer and Nyloc Nut and tighten blades back onto reel.
17. Loosely re-position the bearing on the left end of the blade reel and place the reel back under the Verticutter.
18. Gently lower the rotor housing onto the blades, then loosely fit the bolts holding the bearings onto the shaft, and the housings of the bearings to the rotor housing.
19. Re-fit the injection tube rack.
20. Check that the blades are in line with the injection tube racks, then tighten the bolts holding the bearing housings to the rotor housing.
21. Re-fit the auger drive pulley and the belt and cover.
22. Raise the blades.
23. Re-fit the grub screws holding the left bearing to the shaft.
24. Re-fit rotor drive belts.
25. Re-tension the rotor belts by tightening up the idler pulley.
26. Re-fit the rotor belt guard and pivot wheel arms.

6.2.2 Belt Replacement

Note: Most of the stretch that the belts experience takes place in the first few hours under load conditions after they have been first installed. After fitting new belts it is advisable that the tension be checked regularly in the first few hours of operation. This is especially important for the rotor belts.

6.2.2.1 Rotor Belts

1. Remove pivot wheel arm (1052) and rotor belt guard (1168).
2. Loosen the belt tension by releasing tension from the idler pulley (5314).
3. Remove rotor belts (5325) by easing them off the pulleys (5316 & 1033).
4. Fit new belts.
5. Re-tension belts by tightening up the idler pulley, ensure you lock the idler arm in place again by tightening the locking nut.
6. Re-fit rotor belt guard & pivot wheel arm.

6.2.2.2 Rotor Relay Belts

1. Push clutch lever (1485) all the way forward.
2. Remove the main cover (2775).
3. Remove rotor belts (5325) as described above, but only from the transfer pulley (1033) end.
4. Loosen the de-clutch bracket (1198) on the tension arm (2766) and pivot the de-clutch bracket away from the belts.
5. Ease rotor relay belts (5342) from top pulley (5741).
6. Remove belts and replace with new belts.
7. Tighten the de-clutch bracket back onto the tension arm in the same position as before.
8. Re-fit main cover.
9. Re-fit rotor belts and rotor belt cover as per 6.2.2.1.

6.2.2.3 Gearbox Drive Belt

1. Remove the main cover (2775).
2. As per 6.2.2.2, remove the rotor relay belts, but from the top pulley (5741) only.
3. Remove tension from the belt by loosening the idler pulley and moving it back in its mounting slot.
4. With the tension now off the gearbox drive belt (5709), remove the belt from the gearbox and engine pulleys and feed it off the machine.
5. Fit new transmission drive belt and re-tension the belt as per 6.1.4.
6. Re-fit the rotor relay belts to the top pulley as per 6.2.2.2 and re-fit main cover.

6.2.2.4 Transmission Drive Belt

1. Remove tension from the transmission drive belt (5709) by sliding the idler pulley forward in its mounting slot, then remove the belt from the machine.
2. Re-fit new belt and re-tension as per 6.1.5.

6.2.2.5 Auger Drive Belt

1. Remove the auger belt cover (1353).
2. Take all tension off the belt by loosening the idler pulley bolt and pushing the pulley (0610) to the bottom of the slot.
3. Remove the belt and replace.
4. Re-tension the belt and re-fit the cover.

6.3 Engine Maintenance

Maintenance on the engine should be carried out as per the manufacturer's owner's manual supplied with this machine.

To drain engine oil;

1. First, unbolt the fuel tank (1286) and carefully move the tank onto the top of the engine base (ensuring the fuel lines are not stretched).
2. Place a shallow container near the front of the machine.
3. Raise the back wheels of the machine slightly to angle the engine forward slightly.
4. Have a funnel ready to place under the oil drain hole which is located at the front of the engine. Remove the oil filler cap and loosen the oil drain plug at the front of the engine until oil begins to flow. Guide the oil into the container with the funnel.
5. As oil flow diminishes remove the drain plug completely and allow oil to drain completely.
6. Replace drain plug and re-fill engine with oil as per manufacturer's instructions.
7. Wipe away excess oil from the engine base.
8. Re-fit oil filler cap.
9. Re-fit fuel tank.

6.4 Battery Maintenance

The Contour Sand Injection Verticutters battery should be maintained as follows;

1. Keep the battery top clean, dry and free from corrosive matter.
2. Clean battery terminals, apply grease to prevent corrosion.
3. Do not let the battery stand in a discharged state, it will not recover.
4. Charge the battery once a month when not in use.
5. If the machine is not to be used for a period of time then remove the battery and store in a cool, dry place.

6.5 Maintenance Schedule

During first 4 hours :

- Check tension on blade engagement handle; adjust if required
- Check tension on rotor belts; adjust as required
- Check that bolts on handle assemblies pivot points are smooth in operation, not too loose or too tight
- Generally check for any loose nuts or fittings, especially handle mounts and blade reel mounting bolts

Daily : Before Use

- Check for worn, slipping or damaged belts
- Check for even tyre pressure
- Check for worn or damaged blades
- Check for any loose nuts, bolts and fasteners
- Check engine oil for correct level

Daily : After Use

- Clear rotor blades of any debris
- Clear transmission of any dirt build-up or other debris
- Clear any debris generally, especially from around engine

Every 6 Months



- Check all belts for wear and tension; replace if necessary
- Generally check for any loose nuts or fittings, especially handle mounts and blade reel mounting bolts

Every 12 Months

- Check all belts for wear and tension; replace if necessary
- Generally check for any loose nuts or fittings, especially handle mounts and blade reel mounting bolts
- Replace all belts unless they appear to be in good condition and will last another 12 months

Transaxle Maintenance

- The transaxle fitted to this machine is a sealed hydrostatic unit which should not require attention, just keep it clean and free from debris and ensure cooling fan is intact and functioning properly.

 CAUTION 
Never use high-pressure water units to clean the Contour Sand Injection Verticutter. Using this type of device around bearings, electric actuators, transmissions and engine seals can compromise their integrity and lead to premature failure of these components.

FUEL TANK DIAGRAM

Part No.	Description
1168	Rotor Belt Cover
1206	Rotor Belt Cover Mount
1209	Upper Main Cover Mount
1210	Lower Main Cover Mount
1765	Fuel Tube
2775	Main Cover
2906	Fuel Tank
5687	Fuel Hose
5733	Fuel Gauge Cap
5734	Tank Vent
5735	Vent Grommet
5742	Fuel Vent Hose
A	1/4"UNF x 3/4" Long Bolt
B	1/4" Internal Tooth Washer
C	1/4" Flat Washer
D	5/16"UNF x 3/4" Long Bolt
E	5/16"UNF x 1" Long Bolt
F	5/16" Internal Tooth Washer
G	5/16" Flat Washer

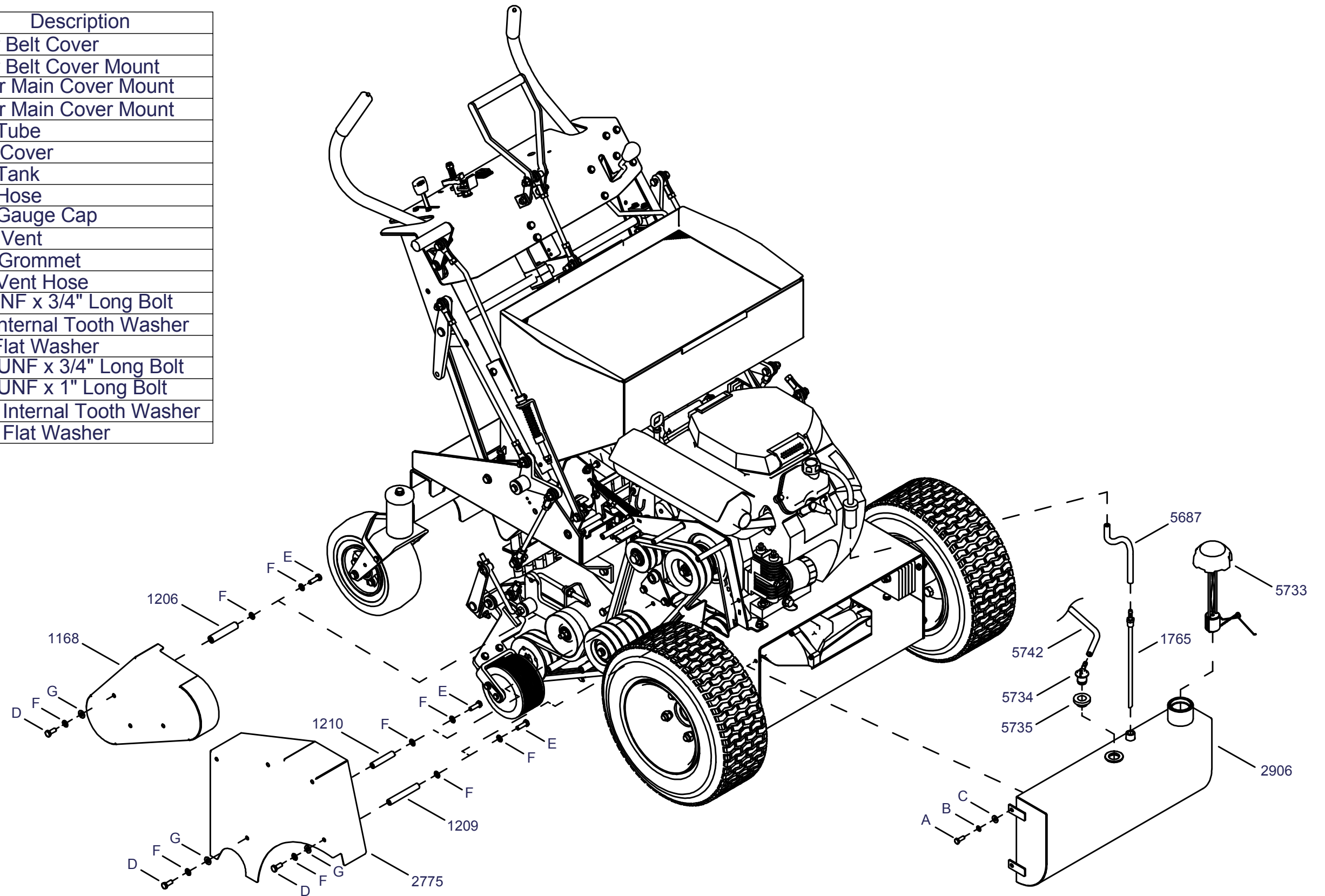

HOPPER DIAGRAM

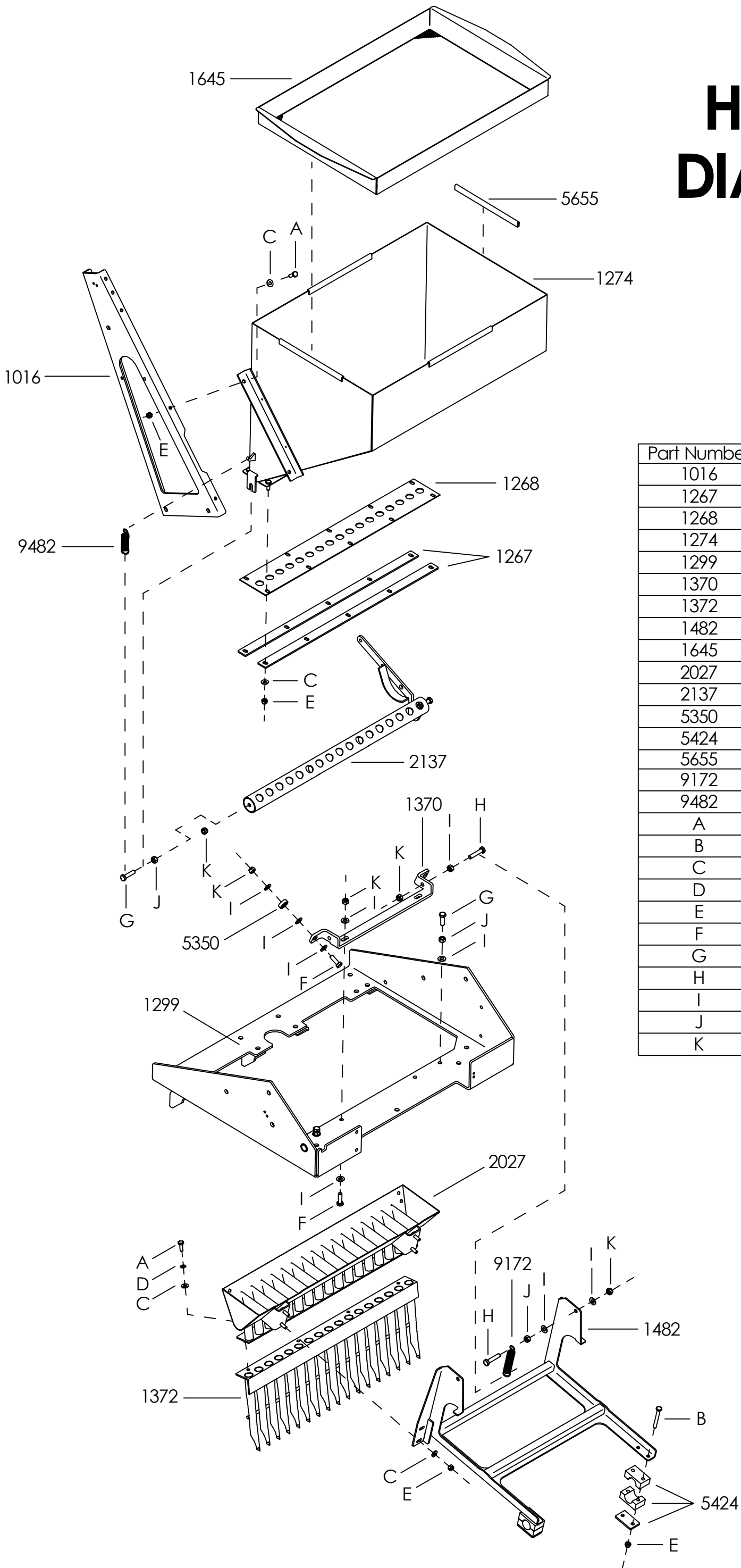

Part Number	Description
1016	Right Hand Control Panel Upright
1267	Strip Clamp
1268	Metering Strip
1274	Hopper
1299	Carriage Bracket
1370	Distributor Tray Guide
1372	Injection Tube Rack
1482	Tray Mounting Bracket
1645	Sieve
2027	Distributor Tray
2137	Hopper Tube
5350	Bearing
5424	25mm Clamp
5655	Pinch Weld
9172	Extension Spring
9482	Extension Spring
A	1/4"UNF x 3/4" Long Bolt
B	1/4"UNF x 2 1/4" Long Bolt
C	1/4" Flat Washer
D	1/4" Internal Tooth Washer
E	1/4"UNF Nyloc Nut
F	5/16"UNF x 1" Long Bolt
G	5/16"UNF x 1/14" Long Bolt
H	5/16"UNF x 1 1/2" Long Bolt
I	5/16" Flat Washer
J	5/16"UNF Hex Nut
K	5/16"UNF Nyloc Nut

Part Number	Description
0508	Rod
0511	Bush (Plated)
0589	Spring Bracket
0614	Slide Bush
0868	1/4" x 70mm Long Key
1032	Double V Idler Pulley
1141	Belt Backrest
1198	De-Clutch Bracket
1202	Idler Bush
1237	Spacer
1343	Upper Clutch Rod
2766	Tension Arm
2767	Clutch Transfer Rod
2772	Outer Support Plate
2774	Clutch Pivot Bracket
2776	Engine Base
2777	Support Plate
5022	1/2" Glacier Bush
5147	Clutch Return Spring
5173	Pressed Metal Balljoint
5181	Compression Spring
5296	Rubber Grommet
5302	3/8" Collar
5315	Taperlock Hub 1610 x 1"
5342	Transfer Pulley Belt
5656	Honda GX630 Engine
5659	Honda GX630 Muffler
5739	Taperlock Pulley 71x1 SPA
5740	Taperlock Bush 1108 x 1"
5741	Taperlock Pulley 100x2 SPB (RE)
9351	Bearing
A	1/4"UNF x 3/4" Long Bolt
B	1/4" Flat Washer
C	1/4" Spring Washer
D	5/16"UNF x 1' Long Bolt
E	5/16" Flat Washer
F	5/16"UNF Nyloc Nut
G	3/8"UNF x 1" Long Bolt
H	3/8"UNF x 1 1/4" Long Bolt
I	3/8"UNF x 1 3/4" Long Bolt
J	3/8"UNF x 2" Long Bolt
K	3/8"UNF x 3" Long Bolt
L	3/8" Flat Washer
M	3/8" Commercial Washer
N	3/8" Internal Tooth Washer
O	3/8"UNF Hex Nut
P	3/8"UNF Nyloc Nut
Q	1/2"UNF x 3 1/2" Long Bolt
R	1/2" Flat Washer
S	1/2"UNF Nyloc Nut

ENGINE BASE DIAGRAM

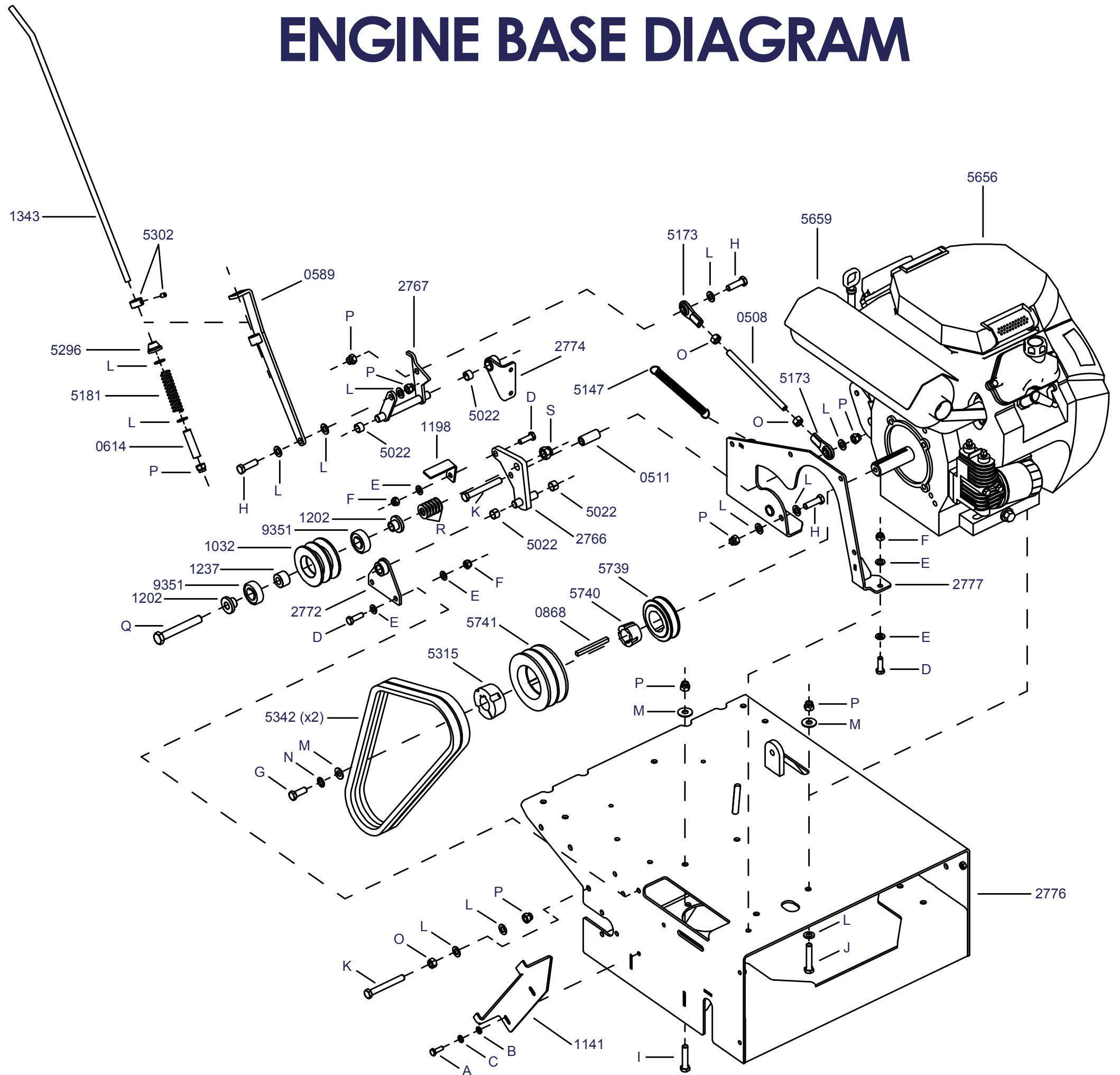

TRANSAXLE DIAGRAM

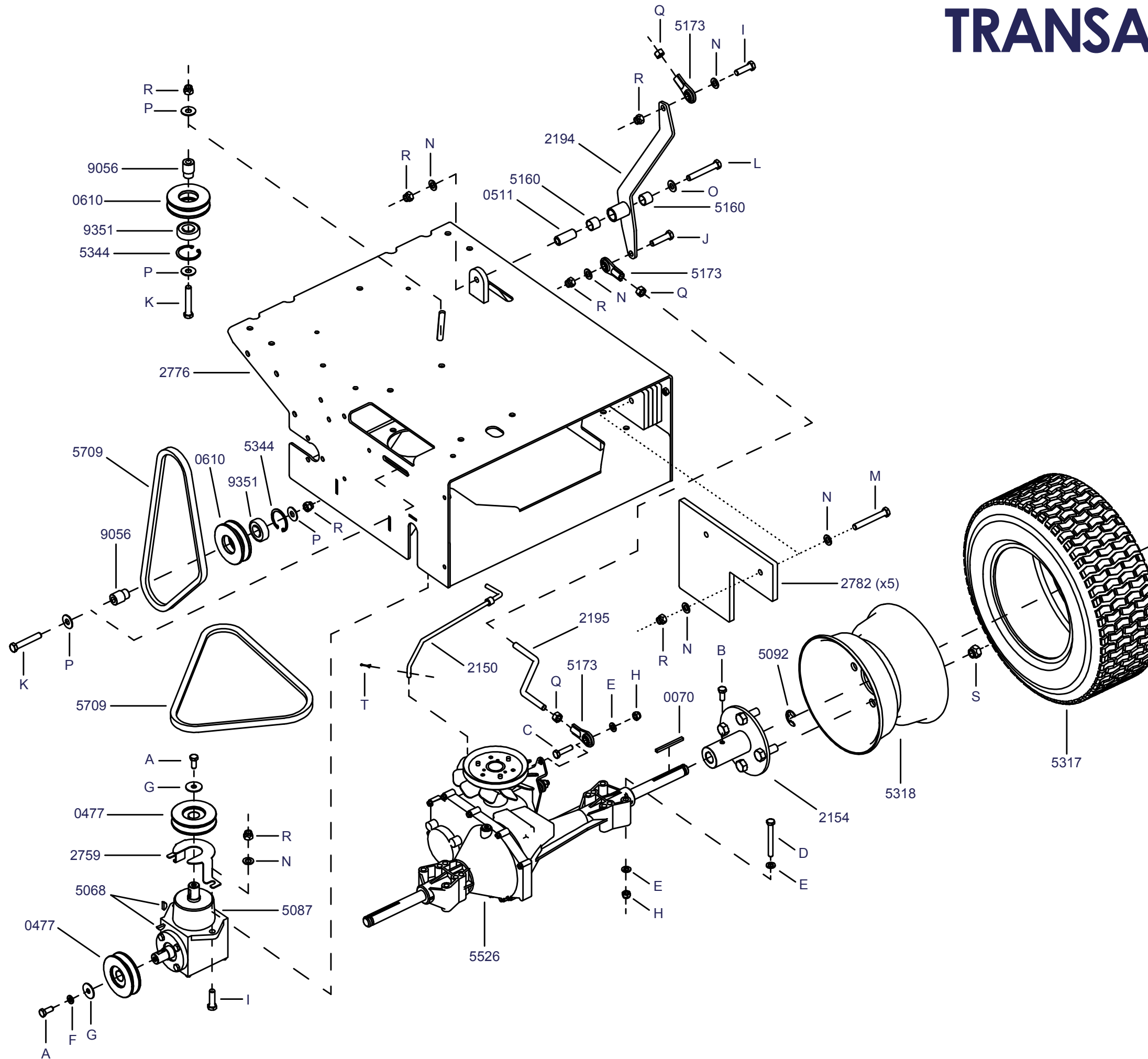

Part No.	Description
0070	3/16" x 60mm Key
0477	Gearbox Pulley
0511	Bush
0610	V Idler Pulley
2150	Neutral Rod
2154	Wheel Hub
2194	Motion Lever
2195	Lower Motion Rod
2759	Seal Retainer
2776	Engine Base
2782	Counterweight
5068	3/16" x 5/8" Woodruff Key
5087	Gearbox
5092	3/4" E-Clip
5160	Bronze Sintered Bush
5173	Pressed Metal Balljoint
5317	Tyre 16x6.50-8
5318	Wheel Rim
5344	40mm Internal Circlip
5526	Transaxle
5709	Drive Belt
9056	Pulley Bush
9351	Bearing
A	5/16"UNC x 3/4" Long Bolt
B	5/16"UNF x 3/4" Long Bolt
C	5/16"UNF x 1 1/4" Long Bolt
D	5/16"UNF x 2 3/4" Long Bolt
E	5/16" Flat Washer
F	5/16" Spring Washer
G	5/16" x 1 1/2" Guard Washer
H	5/16"UNF Nyloc Nut
I	3/8"UNF x 1 1/4" Long Bolt
J	3/8"UNF x 1 1/2" Long Bolt
K	3/8"UNF x 2 1/4" Long Bolt
L	3/8"UNF x 2 1/2" Long Bolt
M	3/8"UNF x 2 3/4" Long Bolt
N	3/8" Flat Washer
O	3/8" Commercial Washer
P	3/8" High Tensile Washer
Q	3/8"UNF Hex Nut
R	3/8"UNF Nyloc Nut
S	1/2"UNF Wheel Nut
T	2mm x 25mm Split Pin

MOTION LEVERS DIAGRAM

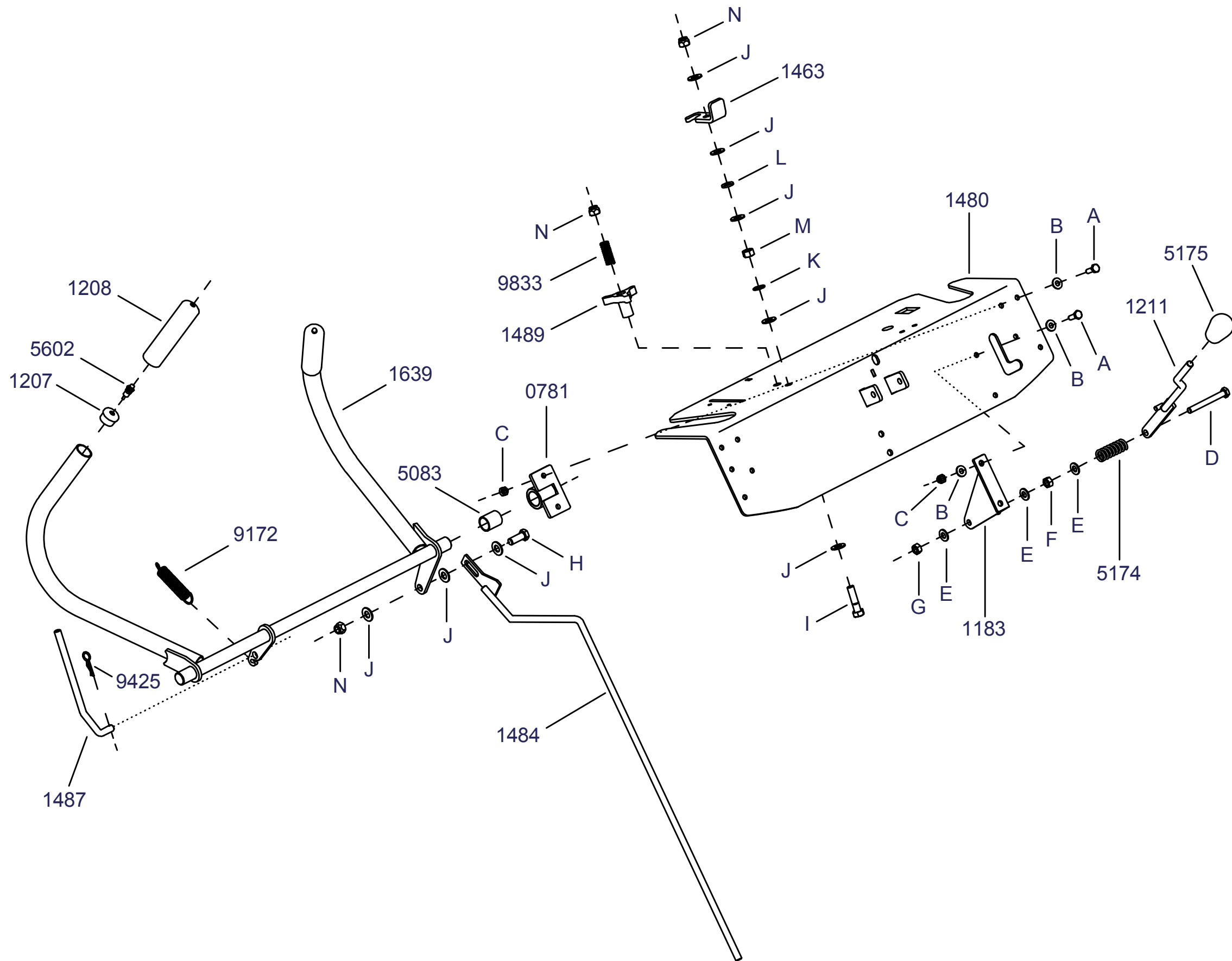

Part No.	Description
0781	Pivot Bar Bracket
1183	Reverse Rod Bracket
1207	End Cap
1208	Handle Grip
1211	Reverse Lever
1463	Speed Gauge Bracket
1480	Control Panel
1484	Motion Rod
1487	Speed Control Rod
1489	Speed Control Adjuster
1639	Control Lever
5083	Bronze Sintered Bush
5174	Compression Spring
5175	Lever Knob
5602	Safety Switch
9172	Extension Spring
9425	2mm R-Clip
9833	Spring
A	1/4"UNF x 3/4" Long Bolt
B	1/4" Flat Washer
C	1/4"UNF Nyloc Nut
D	5/16"UNF x 2 3/4" Long Bolt
E	5/16" Flat Washer
F	5/16"UNF Hex Nut
G	5/16"UNF Nyloc Nut
H	3/8"UNF x 1 1/4" Long Bolt
I	3/8"UNF x 1 1/2" Long Bolt
J	3/8" Flat Washer
K	3/8" Internal Tooth Washer
L	3/8" Spring Washer
M	3/8"UNF Hex Nut
N	3/8"UNF Nyloc Nut

CONTROL LEVERS DIAGRAM

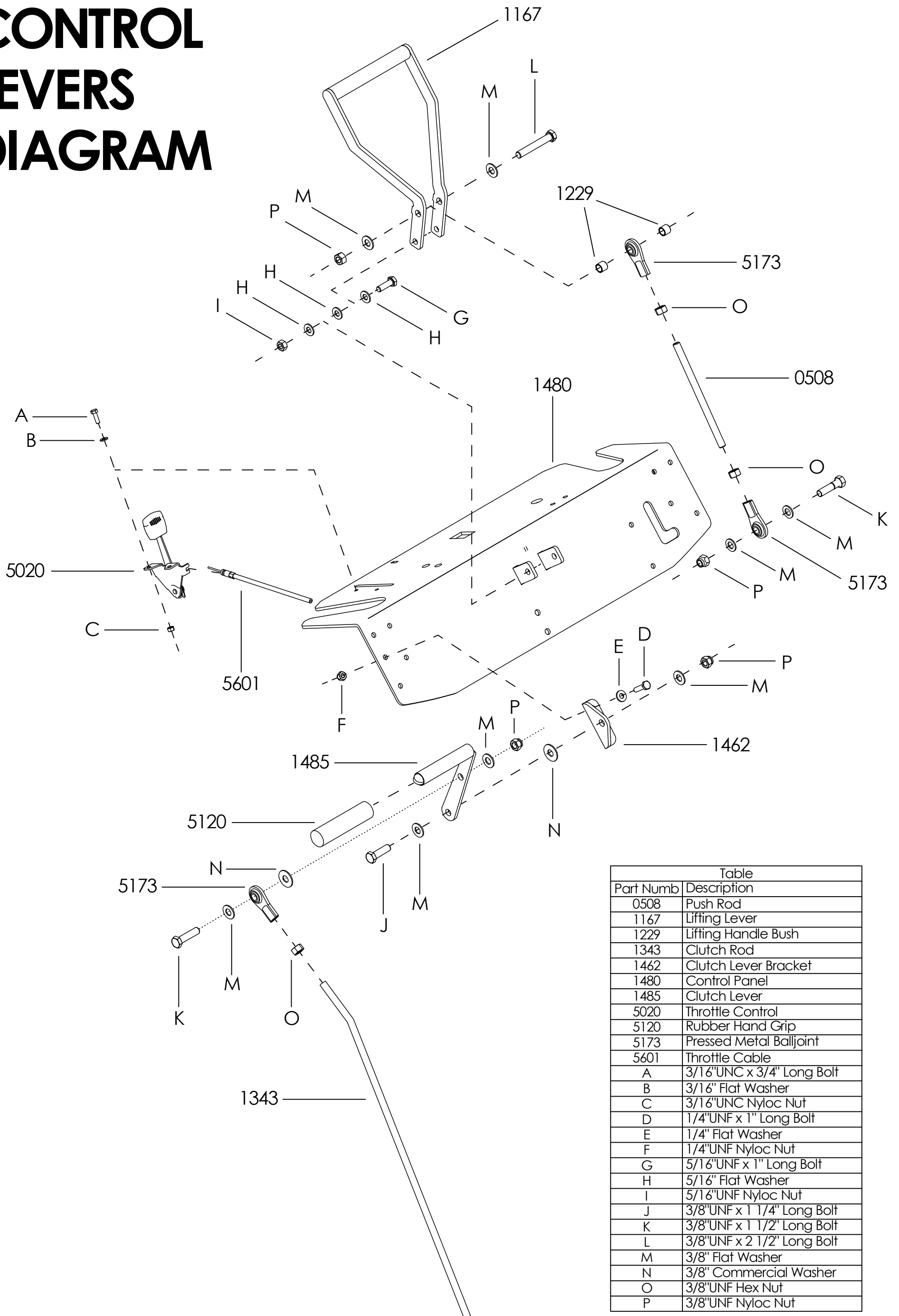
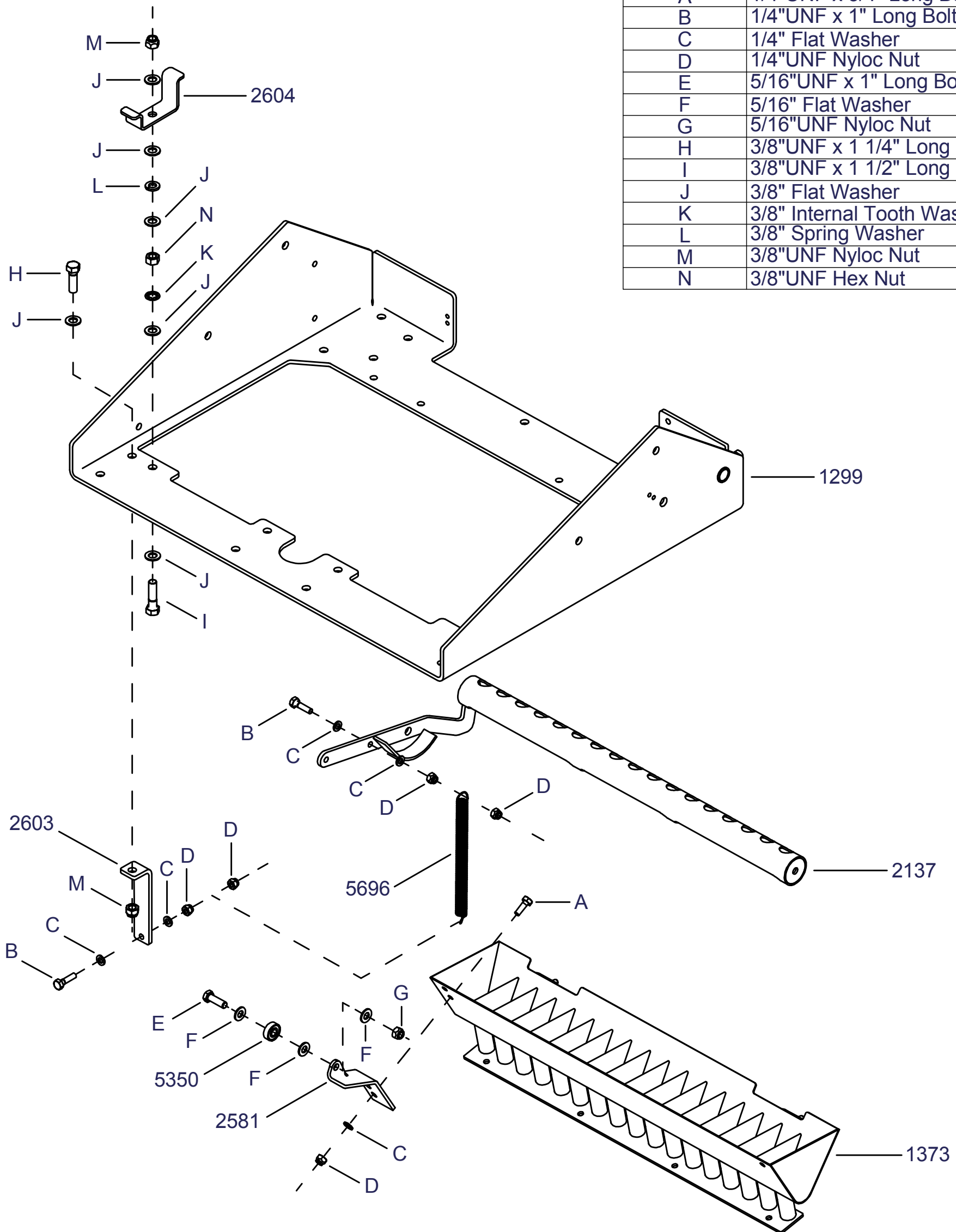
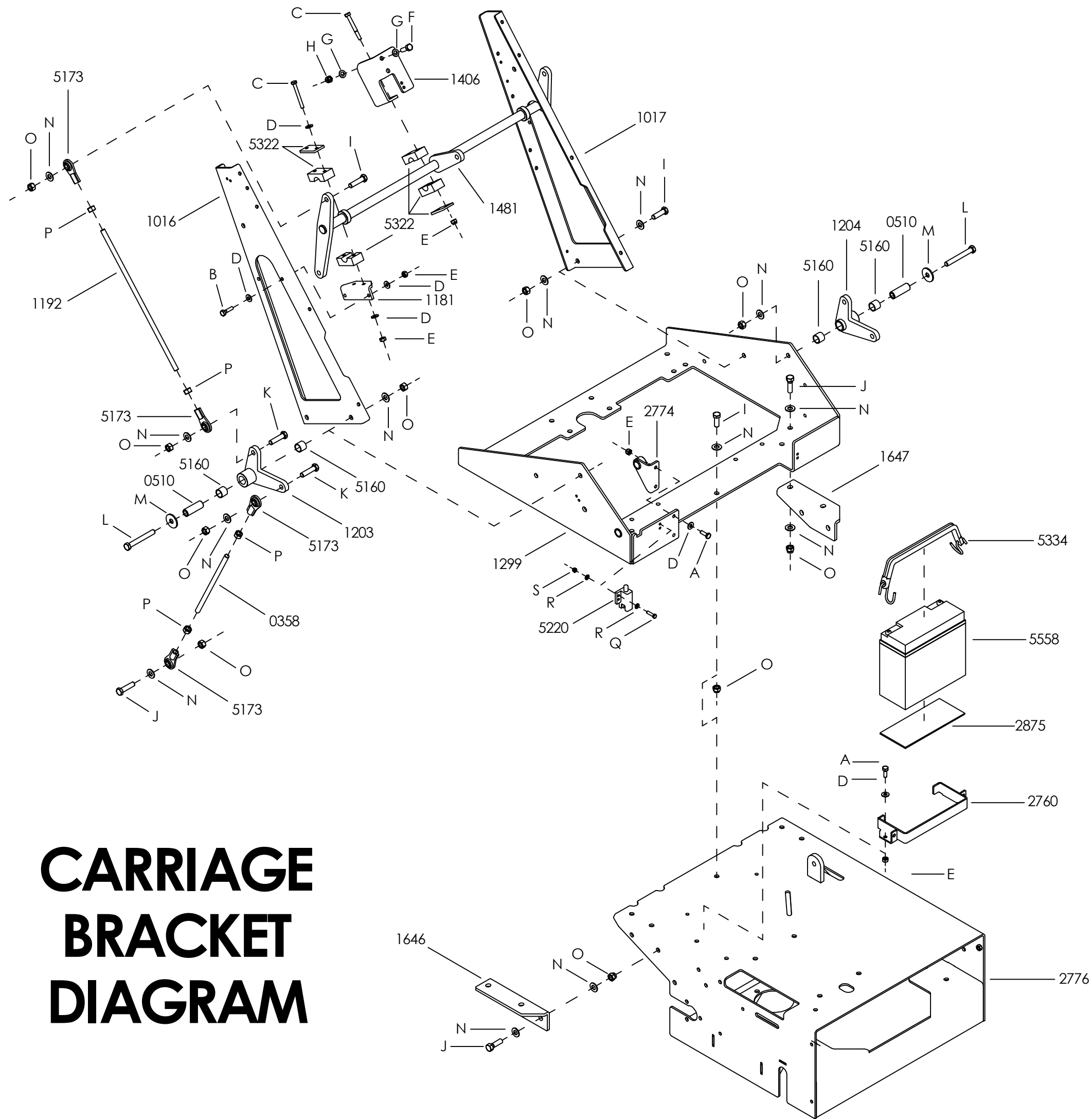

Table	
Part Numb	Description
0508	Push Rod
1167	Lifting Lever
1229	Lifting Handle Bush
1343	Clutch Rod
1462	Clutch Lever Bracket
1480	Control Panel
1485	Clutch Lever
5020	Throttle Control
5120	Rubber Hand Grip
5173	Pressed Metal Balljoint
5601	Throttle Cable
A	3/16"UNC x 3/4" Long Bolt
B	3/16" Flat Washer
C	3/16"UNC Nyloc Nut
D	1/4"UNF x 1" Long Bolt
E	1/4" Flat Washer
F	1/4"UNF Nyloc Nut
G	5/16"UNF x 1" Long Bolt
H	5/16" Flat Washer
I	5/16"UNF Nyloc Nut
J	3/8"UNF x 1 1/4" Long Bolt
K	3/8"UNF x 1 1/2" Long Bolt
L	3/8"UNF x 2 1/2" Long Bolt
M	3/8" Flat Washer
N	3/8" Commercial Washer
O	3/8"UNF Hex Nut
P	3/8"UNF Nyloc Nut

SAND GAUGE DIAGRAM

Part Number	Description
1299	Carriage Bracket
1373	Distributor Tray
2137	Hopper Tube
2581	Sand Flow Tray Bracket
2603	Spring Bracket
2604	Metering Gauge
5350	Bearing
5696	Extension Spring
A	1/4"UNF x 3/4" Long Bolt
B	1/4"UNF x 1" Long Bolt
C	1/4" Flat Washer
D	1/4"UNF Nyloc Nut
E	5/16"UNF x 1" Long Bolt
F	5/16" Flat Washer
G	5/16"UNF Nyloc Nut
H	3/8"UNF x 1 1/4" Long Bolt
I	3/8"UNF x 1 1/2" Long Bolt
J	3/8" Flat Washer
K	3/8" Internal Tooth Washer
L	3/8" Spring Washer
M	3/8"UNF Nyloc Nut
N	3/8"UNF Hex Nut





CARRIAGE BRACKET DIAGRAM

Part Number	Description
0358	Rod
0510	Bush
1016	Right Hand Control Panel Upright
1017	Left Hand Control Panel Upright
1181	Pivot Bar Clamp Bracket
1192	Long Lifting Rod
1203	Right Hand Lifting Quadrant
1204	Left Hand Lifting Quadrant
1299	Carriage Bracket
1406	Support Bracket
1481	Lifting Pivot Bar
1646	Right Hand Deck Brace
1647	Left Hand Deck Brace
2760	Battery Keeper
2774	Clutch Pivot Bracket
2776	Engine Base
2875	Battery Pad
5160	Bronze Sintered Bush
5173	Pressed Metal Balljoint
5220	Safety Switch
5322	Clamp
5334	Battery Strap
5558	Battery
A	1/4"UNF x 3/4" Long Bolt
B	1/4"UNF x 1" Long Bolt
C	1/4"UNF x 2 1/4" Long Bolt
D	1/4" Flat Washer
E	1/4"UNF Nyloc Nut
F	5/16"UNF x 1" Long Bolt
G	5/16" Flat Washer
H	5/16"UNF Nyloc Nut
I	3/8"UNF x 1" Long Bolt
J	3/8"UNF x 1 1/4" Long Bolt
K	3/8"UNF x 1 1/2" Long Bolt
L	3/8"UNF x 3" Long Bolt
M	3/8" x 1 1/4" Guard Washer
N	3/8" Flat Washer
O	3/8"UNF Nyloc Nut
P	3/8"UNF Hex Nut
Q	3/16"BSW x 3/4" Long Bolt
R	3/16" Flat Washer
S	3/16"BSW Nyloc Nut

REAR AXLE DIAGRAM

Part Number	Description
0570	Bearing Spacer
0579	Yoke Bearing Protector
1034	Scraper
1062	Rear Wheel Axle
1069	Short Wheel Spacer
1070	Long Wheel Spacer
1162	Rear Wheel Yoke
1299	Carriage Bracket
1355	Pivot Axle
1601	Kickplate Assembly
5286	Wheel Rim
5321	9x3.50-4 Slick Tyre
5331	9x3.50-4 Tube
5660	Regulator/Rectifier
9352	Bearing
9459	Weather Shield
A	1/4"UNF x 3/4" Long Bolt
B	1/4"UNF x 1 1/4" Long Bolt
C	1/4" Flat Washer
D	1/4"UNF Nyloc Nut
E	M8 x 50mm Long Bolt
F	5/16" Internal Tooth Washer
G	M8 Hex Nut
H	3/8"UNF x 1" Long Bolt
I	3/8" Flat Washer
J	3/8" Internal Tooth Washer
K	3/8" Commercial Washer
L	3/8" x 1 1/4" Guard Washer
M	3/8"UNF Nyloc Nut
N	3/4"UNF x 3 1/2" Long Bolt
O	3/4" Flat Washer
P	3/4"UNF Nyloc Nut

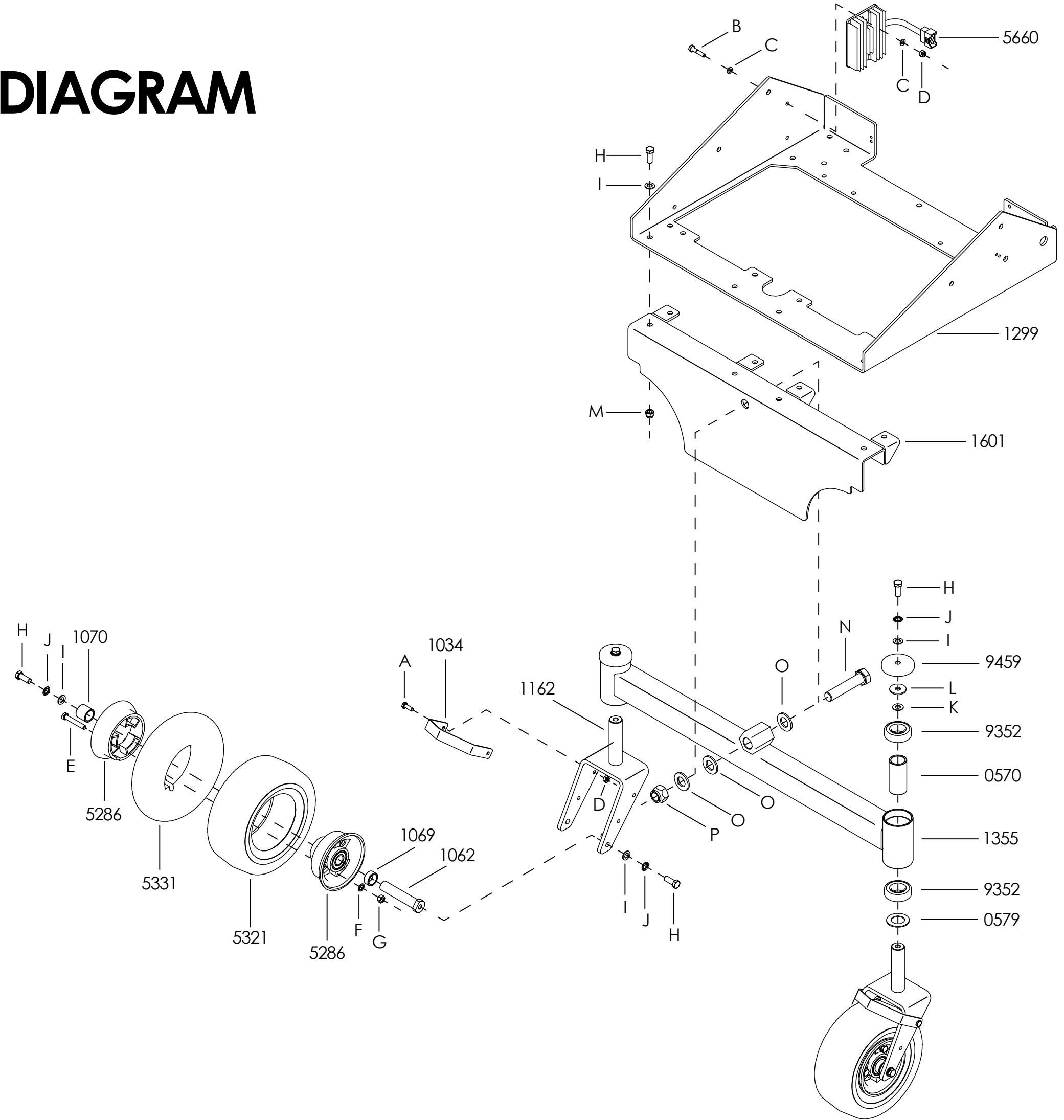

ROTOR HOUSING DIAGRAM

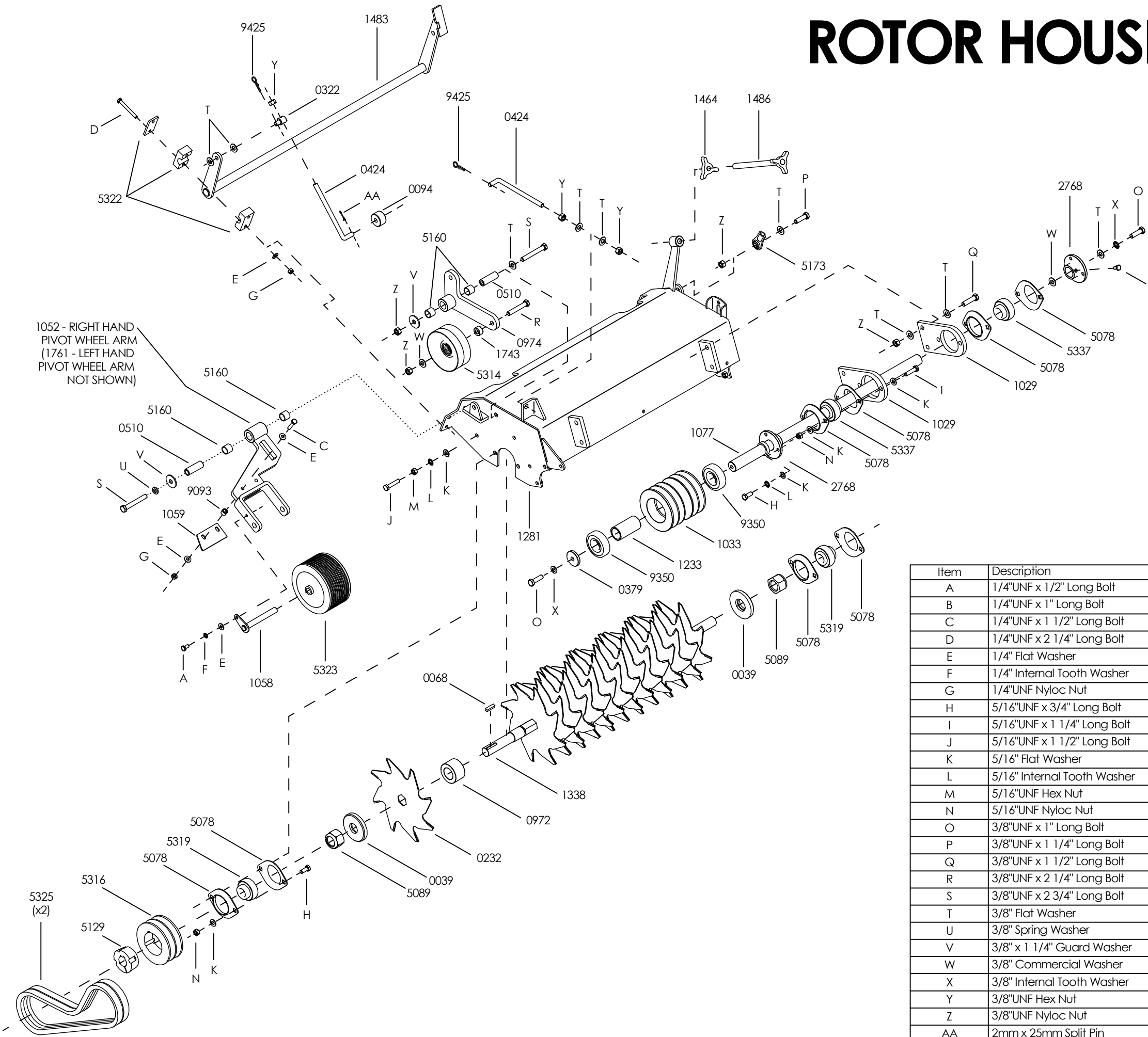

1052 - RIGHT HAND PIVOT WHEEL ARM
 (1761 - LEFT HAND PIVOT WHEEL ARM NOT SHOWN)

Item	Description
A	1/4"UNF x 1/2" Long Bolt
B	1/4"UNF x 1" Long Bolt
C	1/4"UNF x 1 1/2" Long Bolt
D	1/4"UNF x 2 1/4" Long Bolt
E	1/4" Flat Washer
F	1/4" Internal Tooth Washer
G	1/4"UNF Nyloc Nut
H	5/16"UNF x 3/4" Long Bolt
I	5/16"UNF x 1 1/4" Long Bolt
J	5/16"UNF x 1 1/2" Long Bolt
K	5/16" Flat Washer
L	5/16" Internal Tooth Washer
M	5/16"UNF Hex Nut
N	5/16"UNF Nyloc Nut
O	3/8"UNF x 1" Long Bolt
P	3/8"UNF x 1 1/4" Long Bolt
Q	3/8"UNF x 1 1/2" Long Bolt
R	3/8"UNF x 2 1/4" Long Bolt
S	3/8"UNF x 2 3/4" Long Bolt
T	3/8" Flat Washer
U	3/8" Spring Washer
V	3/8" x 1 1/4" Guard Washer
W	3/8" Commercial Washer
X	3/8" Internal Tooth Washer
Y	3/8"UNF Hex Nut
Z	3/8"UNF Nyloc Nut
AA	2mm x 25mm Split Pin

Part Number	Description
0039	Rotor Shaft Washer
0068	1/4" x 25mm Key
0094	Height Adjustment Roller
0232	Cutting Blade (2mm)
0322	Swivel
0379	Thick Washer
0424	Idler Adjuster
0510	Bush
0972	30mm Spacer
0974	Idler Arm
1029	Lower Pivot Bar Plate
1033	Transfer Pulley
1052	Right Hand Pivot Wheel Arm
1058	Pivot Wheel Axle
1059	Pivot Wheel Scraper
1077	Housing Pivot Bar
1233	Transfer Pulley Spacer
1281	Rotor Housing
1338	Rotor Shaft
1464	Mini Locking Lever
1483	Height Adjustment Pivot Bar
1486	Height Adjustment Thread
1743	Pulley Bush
1761	Left Hand Pivot Wheel Arm
2768	Shaft Mounting Bush
5078	Metal Bearing Flange Housing
5089	1"UNF Nyloc Nut
5129	Taper Lock Hub - 1610 x 7/8"
5160	Bronze Sintered Bush
5173	Pressed Metal Balljoint
5314	100mm Flat Back Idler Pulley
5316	Taper Lock Pulley - SPB100 x 1610
5319	7/8" Standard Bearing
5322	Clamp
5323	Plastic Pivot Wheel
5325	Rotor Belt
5337	25mm Standard Bearing
9093	Bush
9350	Bearing
9425	2mm R-Clip

AUGER DIAGRAM

Part Number	Description
0403	Pulley Bush
0610	V Idler Pulley
1205	Exclusion Strip
1232	Exclusion Strip Plate
1348	Deflector Panel
1353	Auger Cover
1488	Auger Endplate
1591	Auger Cover Mount - Top
1592	Auger Cover Mount - Bottom
1637	Auger Shaft
5082	7/8" Bi-Loc Hub
5344	40mm Internal Circlip
5398	20mm Bi-Loc Hub
5423	Auger Drive Belt
9351	Bearing
9370	71mm Bi-Lock Pulley
9374	Bi-Loc Retainer (inc. bolts)
9546	100mm Bi-Loc Pulley
9702	Bearing
A	1/4"UNF x 3/4" Long Bolt
B	1/4" Flat Washer
C	1/4"UNF Nyloc Nut
D	5/16"UNF x 3/4" Long Bolt
E	5/16"UNF x 1" Long Bolt
F	5/16" Flat Washer
G	5/16" Internal Tooth Washer
H	5/16" x 1" Guard Washer
I	5/16" Spring Washer
J	3/8"UNF x 1 3/4" Long Bolt
K	3/8" Commercial Washer
L	3/8"UNF Nyloc Nut

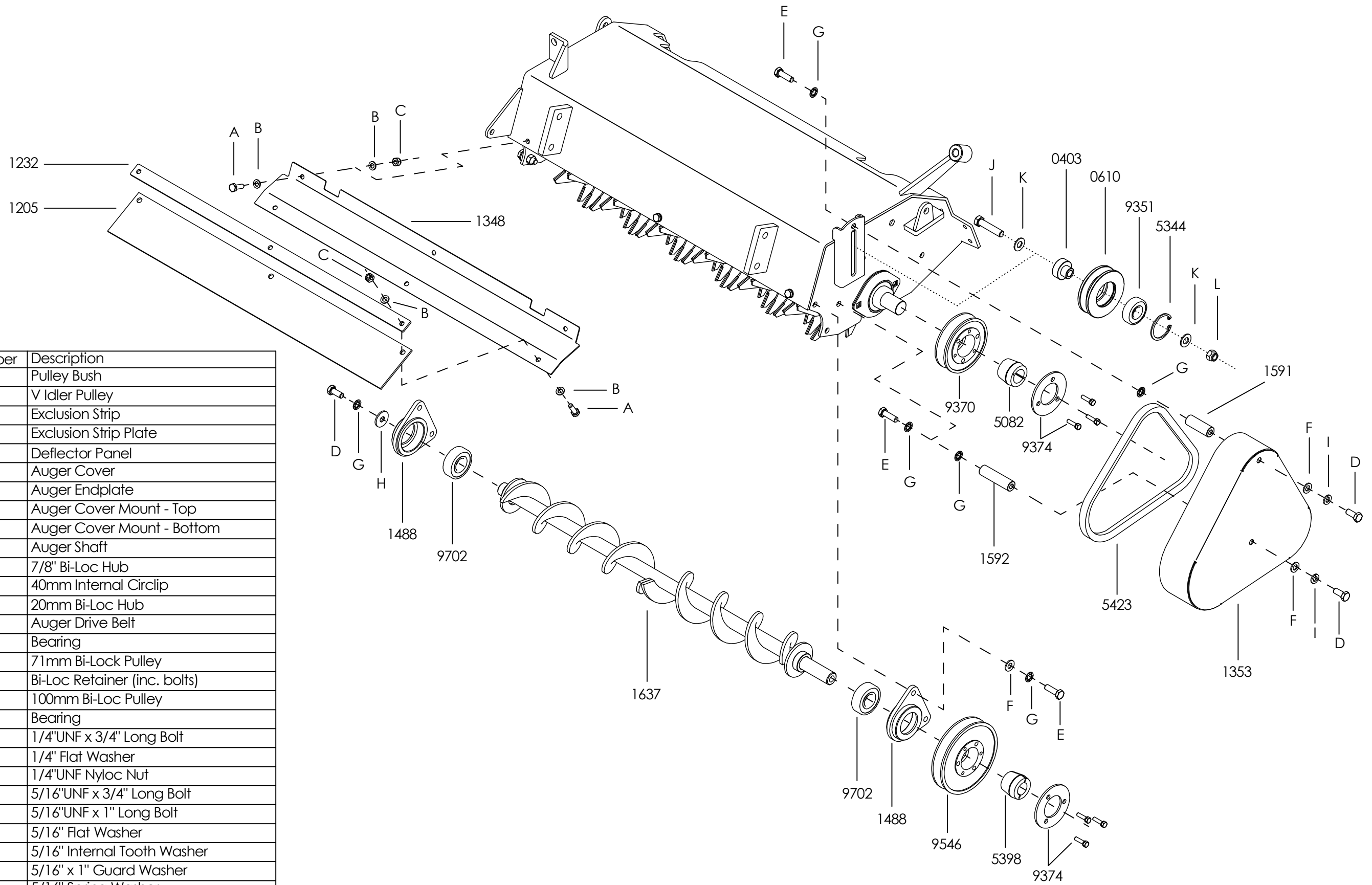

GRADEN CONTOUR SAND INJECTION

WIRING DIAGRAM - GX630 HONDA ENGINE

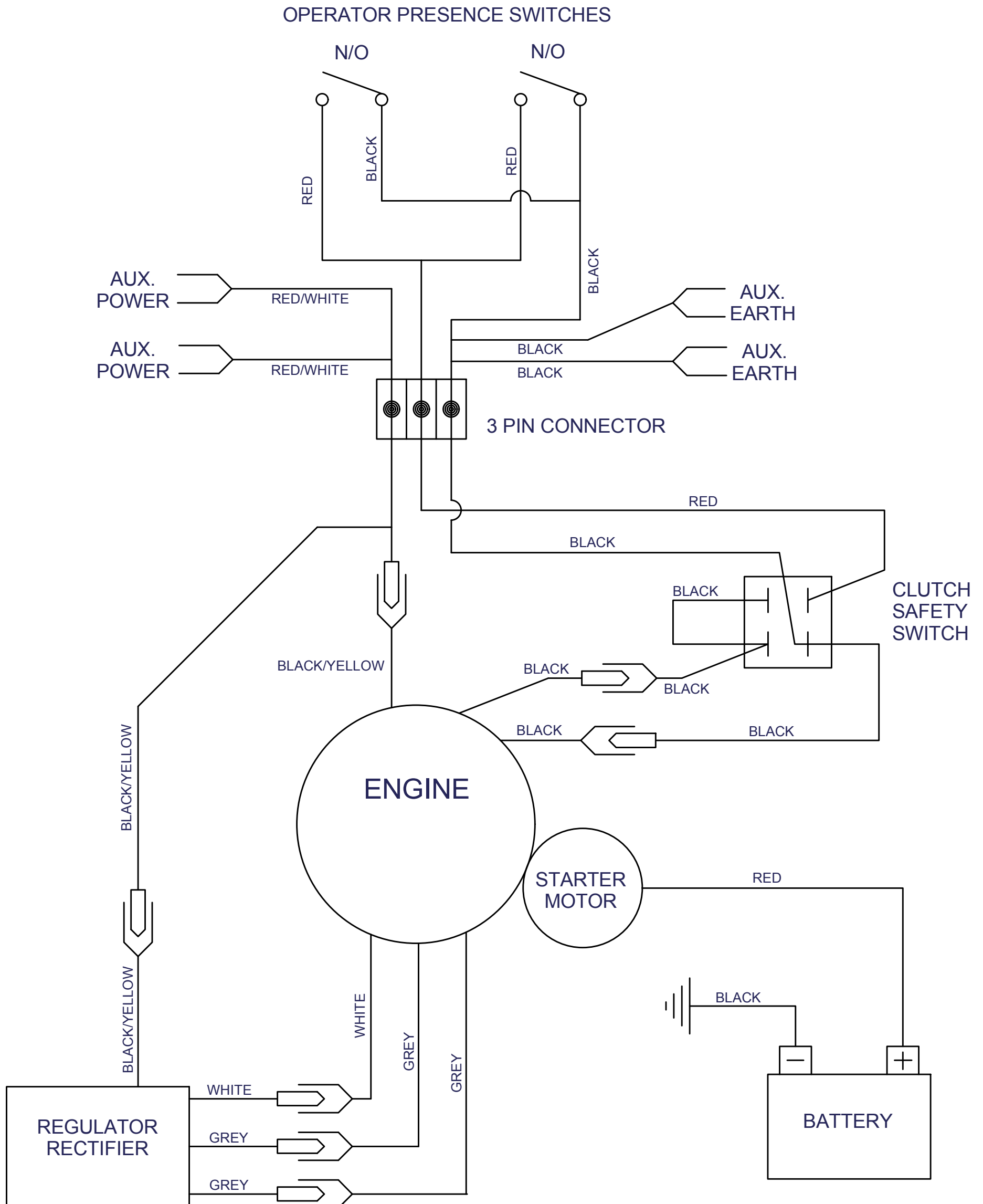

9. Warning/Compliance Decals



PART No. 5312 – Cover Warning Decal (x3)



PART No. 5154 – Danger Decal (x3)



Part No. 5353 – CE Compliance Decal

9. Warning/Compliance Decals (cont'd)



PART No. 5363 – Unleaded Fuel Decal



PART No. 5361 – No Naked Flame/Smoking Decal



PART No. 5364 – Muffler Warning Decal (x2)



PART No. 5362
Advisory Hearing Protection Decal