

GRADEN

INDUSTRIES PTY LTD

GBS 1200

**OFFSET - TRACTOR MOUNTED
VERTICUTTER/SCARIFIER**

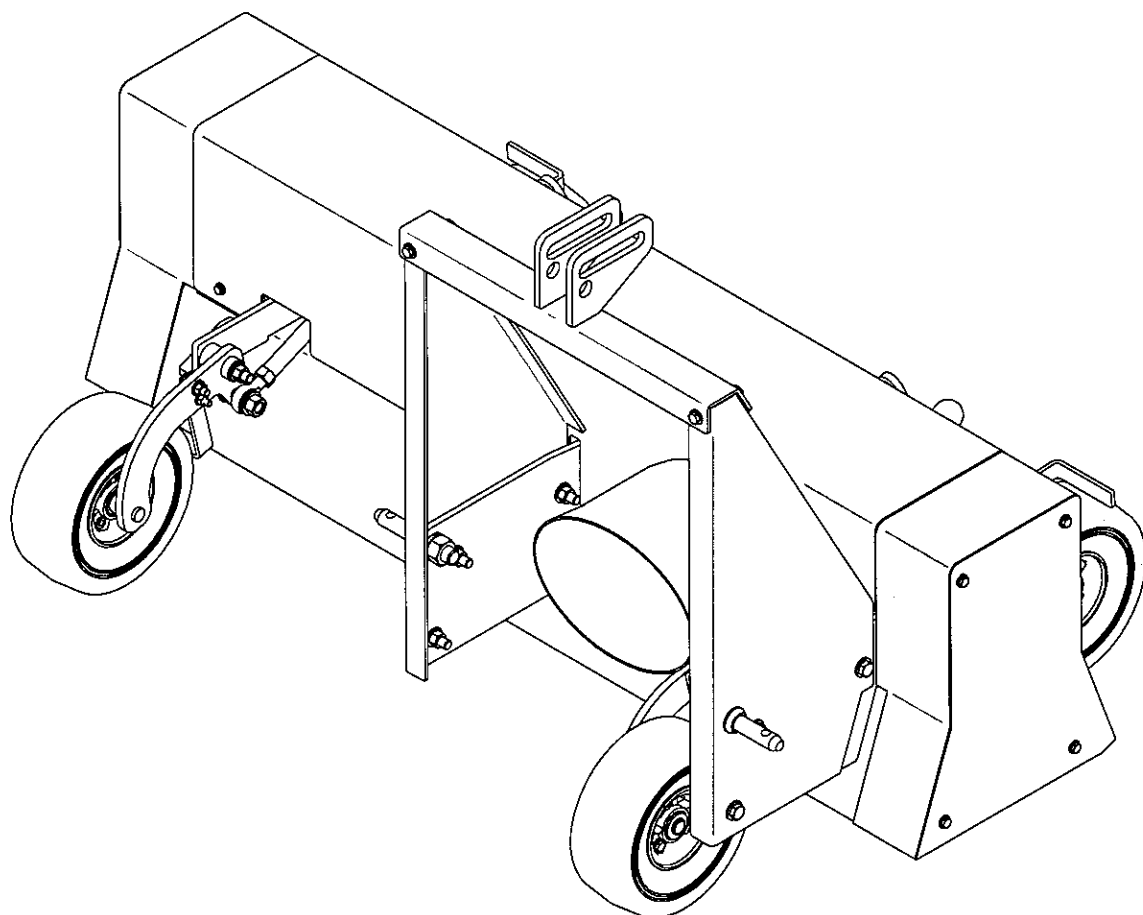

OWNERS MANUAL

Table of Contents

1. Specifications

- 1.1 Specifications
- 1.2 Statement of Machine Use
- 1.3 Serial Number Plate

2. To the Owner

- 2.1 Preliminary instructions
- 2.2 Warning symbols
- 2.3 Servicing the GBS 1200 Verticutter

3. Safety Information

- 3.1 General rules
- 3.2 Training
- 3.3 Personal Protective Equipment (PPE)
- 3.4 Preparation
- 3.5 Operational Safety
- 3.6 Maintenance Safety

4. Assembly Instructions

5. Operating Instructions

- 5.1 Preliminary checks
- 5.2 Set up
- 5.3 Transporting (traversing) the Verticutter
- 5.4 Verticutting
- 5.5 Shut down

6. Maintenance Operations

- 6.1 Adjustments and settings
- 6.2 Replacements
 - 6.2.1 Blade replacement
 - 6.2.2 Belt replacement
- 6.3 Gearbox & P.T.O. Shaft
- 6.4 Maintenance schedule

7. Warranty

8. Parts & Illustrations

- 8.1 Diagrams
- 8.2 Warning/Compliance Decals

1.1 Specifications

Model	Graden GBS 1200 Offset Verticutter
P.T.O. Horsepower	20 - 35 h.p.
Drive	PTO shaft drive from tractor to gearbox Belt drive to rotor shaft
Gearbox	Comer T27A Gearbox
Gearbox oil	Gear Oil SAE 80W90
Cutting Reel	1 Fixed - 39 blades (standard)
Cutting width	1220mm (48 inches)
Cutting depth (nominal)	0-45mm
Blades Standard : Optional : Optional :	Tungsten carbide tipped - spring steel 210mm x 2mm tip Part No. 0232 210mm x 3mm tip Part No. 0217 210mm x 1mm tip Part No. 1122
Blade tip speed	1250m/min (standard blades at normal PTO speed of 540 rpm)
Weight	240 kg (approx.)
Height	1000 mm
Overall Width	1540 mm
Tyres	4.10/3.50 - 4 Slick Pattern (4 per machine)
Tyre pressure	140 kPa / 20 psi (50 psi maximum)
Rotor belts	AX40 Dayco Gold Label (6 per machine)

1.2 Statement of Machine Use

The Graden GBS 1200 Verticutter/Scarifier's main use is as a verticutting/scarifying/de-thatching tool on areas such as tennis courts, bowling greens, cricket wickets, golf courses and other sporting fields.

It is not for use on turf areas where rocks and other hard foreign bodies may be present. The use of this machine in turf profiles of this nature will likely cause premature wear or shattering of the blades and blade tips and could result in rocks being projected at dangerous speeds, resulting in potential injury to the operator or damage to the machinery.

This machine is not for use in anything other than the soil profiles typically to be found on the sporting fields mentioned above. Any use of this machine in any other type of surface or for any other purpose may void the warranty.

Please contact Graden Industries if you are unsure about your application complying with the intended use of this machine.

1.3 Serial Number Plate

The serial number plate layout is shown below. The serial number is comprised of four sections. The first section is the model number, the second section is the mass of the machine, the third section is the serial number and the fourth section is the year of manufacture of the machine, as indicated below;

GRADEN	
INDUSTRIES PTY LTD	
26 - 28 SCAMMEL STREET	
CAMPBELLFIELD VICTORIA 3061	
MADE IN AUSTRALIA	
MODEL N ^o _ _ _ _	MASS _ _ _ _
SERIAL N ^o _ _ _ _	YEAR _ _ _ _

2. To the Owner

Read this manual before operating the GBS 1200 Verticutter

2.1 Preliminary Instructions

- It is important that the owner completely familiarises themselves with the contents of this manual
- Keep this manual at hand as a ready reference for anybody using the Graden GBS 1200 Verticutter
- The designed and tested safety features of this machine are dependent on it being operated within the limitations described in this manual

2.2 Warning Symbols

Throughout this manual the following symbols are used to indicate important safety issues. When either or both of these symbols are present the operator must be aware that there is the potential to damage equipment and/or incur serious personal injury.

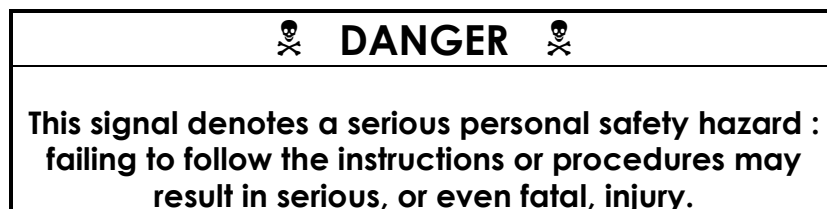
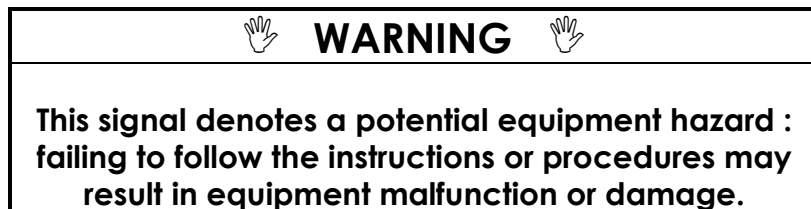

2.3 Servicing the GBS 1200 Verticutter

The Graden GBS 1200 Verticutter has been carefully engineered and manufactured to provide safe, dependable and effective service.

As with all mechanical equipment it requires routine cleaning and maintenance.

Your authorised Graden representative has access to tools, genuine spares and equipment to service any and all of your requirements.

Use only genuine Graden parts ; substitute parts will void the warranty and may not meet the safety and performance standards required for safe and effective operation of the GBS 1200 Verticutter.

Please record the model and serial numbers of the GBS 1200 Verticutter in the space provided below and quote this information when ordering parts or communicating with Graden Industries or its' approved representatives.

Model Number :

Serial Number :

Date Purchased :

3. Safety Information

This manual is provided to help you operate and maintain the GBS 1200 Verticutter. Please read it carefully.

It has been compiled from extensive field experience and engineering data.

In some aspects it is generalised because it is impossible to cover all operating scenarios. However, combining the information provided in this manual with your own increasing experience and knowledge with the GBS 1200 Verticutter will enable you to develop procedures suitable for your individual needs.

The GBS 1200 Verticutter, like most modern machinery, is constantly undergoing development on the basis of experience and market needs. At the time of printing, material in this manual was current but may vary due to the aforementioned ongoing development.

Graden Industries reserve the right to change the machinery specifications without notice.

3.1 General Rules

- Direction on the machine (right or left) is determined from standing behind the machine and facing in the direction of forward travel
- When viewed from the right side the blades rotate anti-clockwise (counter rotating to the forward rotation of the tractor wheels)
- This is a precision piece of machinery with high speed cutting blades

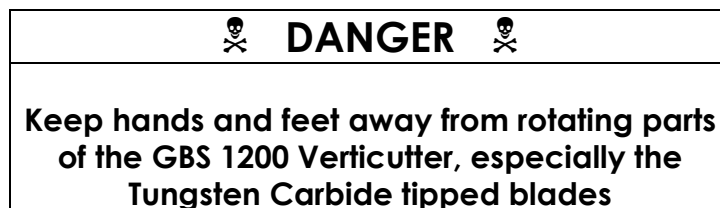

- Do not allow children to operate the machine or be near it during its' operation.

- Never allow anyone to ride on the GBS 1200 verticutter at any time.
- Only people who are very familiar with the rules of safe operation should be allowed to use this machine
- Only use the machine during daylight or in good artificial light
- For clarity, some illustrations in this manual show the GBS 1200 Verticutter with safety guards removed. This is not a normal situation.

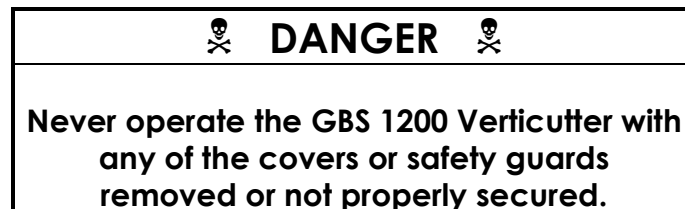

3.2 Training

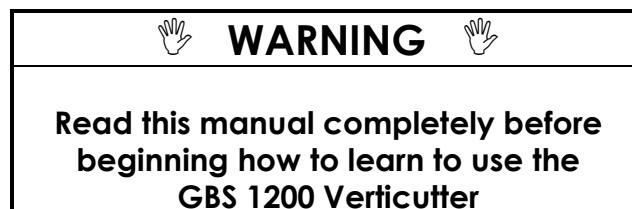

- Do not allow anybody to operate the machine without instruction
- Know your controls and how to stop the machine and shut down the tractor quickly in an emergency
- To maintain control and reduce the possibility of upset, damage or collision, operate the machine smoothly. Avoid erratic operation and excessive speed.

- The tractor has its' own set of safety and operating rules. These must be complied with.



- If the tractor is fitted with a Roll Over Protection Structure (ROPS), do not exceed the ROPS weight certification and always wear your seat belt.
- Be aware of the hazards associated with the tractor engine :
 - ⇒ The fuel used (Petrol, diesel, etc.) is highly flammable so only use an appropriate container
 - ⇒ Never remove the fuel cap or add fuel while the engine is running or still hot
 - ⇒ Never add fuel indoors and wipe up any spillages
 - ⇒ Never run the engine in an enclosed area because exhaust gases are toxic

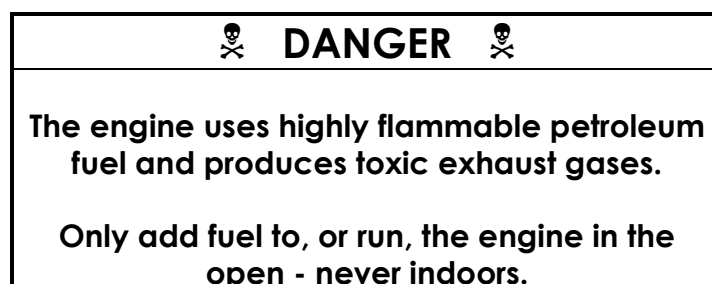

3.3 Personal Protective Equipment (PPE)

- Clothing should be reasonably snug fitting and not free flowing so as to avoid the risk of entanglement in moving parts.
- Wear sturdy footwear, preferably steel capped safety shoes or boots
- Use appropriate PPE for eyes, ears and hands



3.4 Preparation

- Ensure all safety warnings and decals are in place and legible (on both the GBS 1200 Verticutter and the tractor).
- Ensure that the GBS 1200 Verticutter is correctly mounted on the tractor and that the machine is properly adjusted.
- Remove any accumulated debris that might represent a fire hazard.
- Ensure that the blades are in a serviceable condition and that the rotor shaft mounting bolts are secure.
- Perform any appropriate scheduled maintenance before operating the machine.

3.5 Operational Safety

- Always disengage the P.T.O before attempting to start the tractor.
- Always raise the GBS 1200 Verticutter clear of the turf before attempting to engage the P.T.O.

- Always raise the GBS 1200 Verticutter clear of the ground and disengage the P.T.O when crossing gravel, walkways, roads, etc.. or indeed any ground which you do not wish to verticut.
- Be very careful and maintain minimum ground speed when operating over rough ground, around trees, ditches, fences or on sloping ground.

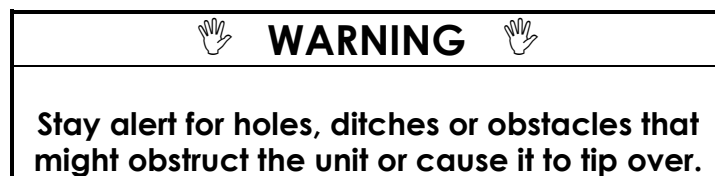

- Never allow anybody in front or behind the tractor and GBS 1200 Verticutter while operating. Before reversing, disengage the P.T.O. then lift the verticutter clear of the ground and ensure that the area behind you is clear.

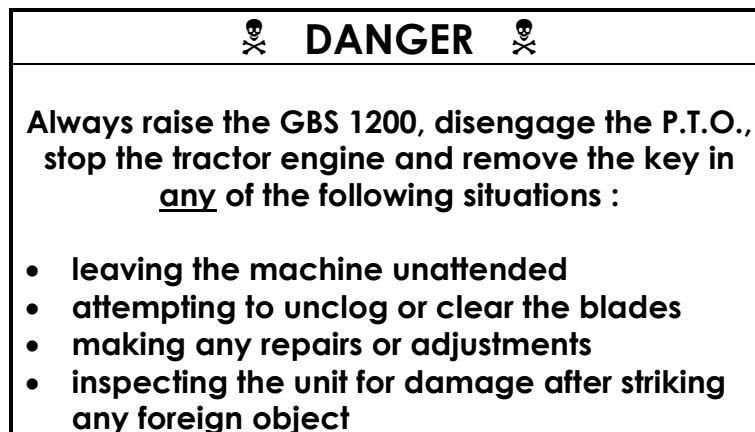

- Always repair any damage before recommencing operation.

3.6 Maintenance Safety

Maintenance on the GBS 1200 Verticutter is best carried out with the machine raised to the maximum height via the adjusting levers at the

back of the machine.

Alternatively, maintenance can be carried out with the unit mounted on the tractor, so long as it is securely blocked up on jack stands. Do not rely on the tractor hydraulics to maintain the unit at a safe working height.

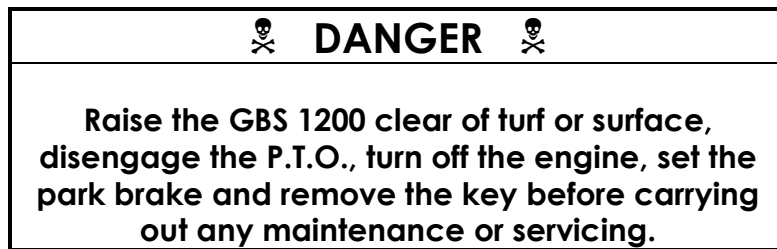

- Never allow anybody near the tractor controls while adjustments, maintenance or servicing are being performed.
- Keep both the GBS 1200 and the tractor (especially around the engine) free of any debris
- Remove debris from underneath the GBS 1200 Verticutter after each use.
- Verify that all warning labels and decals are present, visible and legible.
- Periodically check that all bolts, fasteners and catches are secure and in safe operating condition.
- After any maintenance or servicing, ensure that all guards and safety devices are correctly installed and secure before operating the GBS 1200 Verticutter.

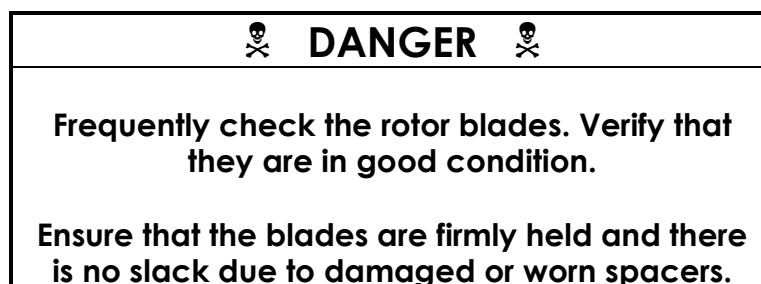

4. Assembly Instructions

Your Verticutter has been manufactured, assembled and tested at Graden Industries before being shipped.

Depending on your local distributor, your Verticutter will have been partially disassembled prior to dispatch. Your machine is most likely to be received in the following condition :

- * Left & right hand uprights removed
- * Crossbar removed
- * Wheel assemblies removed and scrapers fitted for transit
- * Oil added to gearbox (gear oil SAE 80W90)
- * P.T.O shaft disconnected

As appropriate, please carry out the following assembly instructions.

Tools required : Circlip pliers
 ½ inch AF spanner (2 off)
 9/16 inch AF spanner (2 off)
 ¾ inch AF spanner (2 off)
 1 ¼ inch AF spanner

Steps

1. Remove all packaging material

2. Re-attach wheels/scrapers

Remove the scrapers (1000) which are fitted for transit. Remove the circlips (5067) from the axles, and the first washer, then slide the wheel assemblies onto the axles. Replace the washer and circlip.

Note : Fit the front left wheel first, as this must be fitted before the other wheels. After this wheel is on, adjust the height screws (0986) to allow you to fit the remaining wheels easier. Re-fit the scrapers (1000) as indicated in the Gearbox & Wheel Arm Diagram.

3. Left & Right Hand Uprights and Crossbar

Attach the left and right hand upright plates (0914 & 0915) as shown on the diagrams, but leave the bolts loose. Bolt the crossbar (0983) to the top of the uprights as indicated in the diagrams. Tighten the bolts up on the crossbar, then on the Uprights.

4. Bottom Links

Fit the bottom links (5285) to the uprights as shown in the cover diagram.

5. Operating Instructions



5.1 Preliminary Checks

1. Clear any debris from above and underneath the machine
2. Ensure scheduled maintenance activities have been completed.
3. Inspect belts for condition and correct tension.
4. Inspect blades for wear or damage.
5. Ensure all guards and covers are firmly fixed in place

5.2 Set Up

1. Ensure that the GBS 1200 is on firm, level surface
2. The cutting depth is set via the two adjusting screws (0986) at the back of the machine. Set your required depth by turning these screws simultaneously, clockwise for lesser depth or anti-clockwise for greater depth. Before mounting onto the tractor you could set your depth by placing all four of the machines wheels on timbers or bricks so the blades can safely be lowered below the tyre level i.e. so they would be travelling into the ground when the machine is resting on the four wheels. As long as the four wheels are raised at the same height, you will be able to check your depth of cut.
3. When the desired depth has been reached turn the locking levers (0970) on both adjusting screws around until they lock onto the trailing arm assembly (0965).
4. Position the tractor in front of the GBS 1200 and lower the tractor 3-point hitch.
5. Attach the lower tractor arms to the bottom links, secure with 3/8" lynch pins and connect the upper tractor arm.
6. Adjust the tractor sway bars so that there is no side-to-side motion.
7. Raise the GBS 1200 off the ground and verify that the unit is level.
8. Attach the P.T.O shaft to the GBS 1200 and then to the tractor, ensuring that both locking pins pop up.
9. Secure the P.T.O guard retaining chains at both ends.

 **DANGER** 

The P.T.O retaining chains must be connected to prevent the outer guard from rotating with the P.T.O shaft

5.3 Transporting (Traversing) the GBS 1200 Verticutter

1. Raise the GBS 1200 clear of the turf (ground).
2. Disengage the P.T.O
3. Drive smoothly to your next destination. Avoid excess speed, especially over rough or uneven ground.

5.4 Verticutting

1. Set the depth of cut via the 2 height adjustment screws (0986), as described in 5.2, at the approximate desired depth. Normal range of cut (with standard 210mm blades) is 0mm to 45 mm deep.
2. Start the tractor, raise the Verticutter clear of the turf and with the engine at idle gently engage the P.T.O
3. Set the P.T.O. speed to 540 rpm – maximum revs.
4. Gently lower the GBS 1200 to the ground and allow the rotating blades to pull themselves into the turf.
5. Make a test cut on level ground of a few metres and check that the Verticutter is cutting to a consistent depth across the full width of the cut.
6. Adjust the height adjustment screws (0986) at the rear of the machine if the blade depth is not even across the machine.
7. Repeat the short test cut and verify that the cut is even across the Verticutter and that the depth of cut is satisfactory.
8. Forward speed will be determined by such variables as: depth of cut, soil hardness, soil texture, moisture content of soil, degree of thatch, smoothness of ground, etc. If you are only lightly dethatching then a forward operating speed of 5 - 10 kmh should be achievable. Deeper cutting requires slower operation. Experience will establish your optimal operating speeds at different cutting depths.
9. In general, you should start with the tractor gear set to Low 2. From this setting you can work out if you can operate at a higher gear, all the way up to High 1 for light de-thatching.
10. Steer the tractor in a straight line while the blades are cutting. Trying to change direction while the blades are in the turf may lead to a furrowing/scalping action and can put undue stress on the

machine, in particular the blades.

11. At the end of a pass :

- raise the blades clear of the turf
- turn the tractor around to make your next run
- gently lower the blades into the ground
- drive forward, maintaining an even forward speed

12. When travelling from area to area raise the blades and disengage the P.T.O. Always drive smoothly to avoid unnecessarily bouncing the machine around.

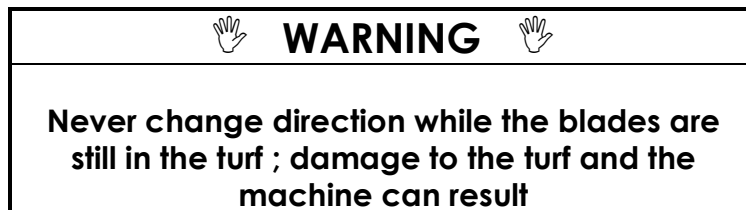



5.5 Shut Down



1. Raise blades out of turf.
2. Disengage P.T.O.
3. Traverse machine to storage/maintenance area.
4. Generally clean the GBS 1200 Verticutter, making sure that there is no accumulated debris around the blades and P.T.O.
5. When finished you can put the machine on boards or bricks so the machine can be left at the operating depth without screwing out the adjustment levers, this is suggested if the machine is to be used again in a short while at the same depth of cut.
6. If the machine is to be stored away then you will probably want to turn the adjustment screws clockwise to raise the machine to its full height. This will enable the machine to be pushed around on its four wheels.
7. Disconnect the P.T.O and demount from the tractor.

6. Maintenance Operations

The performance of certain maintenance, adjustment or repair operations will be determined by the owner's facilities.

Work can be carried out with the machine supported on its own wheels or, alternatively, with the machine still attached to the tractor.

 WARNING 
If the GBS 1200 is left on the tractor, under no circumstances rely on the tractor hydraulics.
Securely block up the machine with jack stands before attempting any maintenance.

 DANGER 
Raise the GBS 1200 clear of turf or surface, disengage the P.T.O., turn off the engine, set the park brake and remove the key before carrying out any maintenance or servicing.

6.1 Adjustments and Settings

The P.T.O. from the tractor drives the gearbox, which in turn drives the blade reel via two sets of drive belts.

1. Remove the side belt covers (0984 & 0985).
2. Adjust the tension by loosening the lock nut on the idler adjuster (0424) and screwing the adjusting nut on the end. Re-tighten the lock nut when correct tension is achieved.
3. **Note** : The recommended tension is 1.0 - 1.5 Kgf (2.2 - 3.3 lbf) to give a deflection of 6mm (1/4 in.) in one of the belts at the mid point between the two pulley centres. This force is approximately the maximum that can comfortably be applied using just the index finger on one belt.
4. Re-fit the belt covers.

6.2 Replacements

These operations are best carried out with the Verticutter mounted to the tractor, but with the P.T.O. Shaft disconnected.

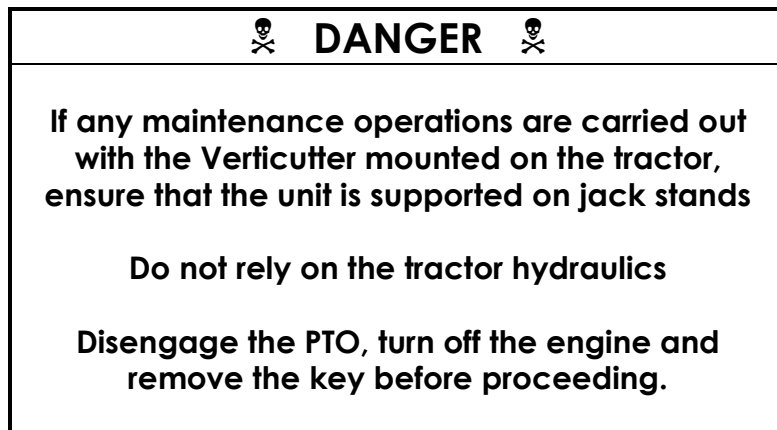

6.2.1 Blade replacement

1. Remove both side belt guards (0984 & 0985)
2. Slacken idler arm adjuster (0424) to remove tension on belts
3. Remove belts (5164) from rotor shaft pulley (5128)
4. Undo the bolts holding the bearing housings (5025) at each end of the blade reel.
5. Drop the blade reel out of the machine, being careful not to damage the blades.
6. Lift the machine clear of the blade reel.
7. Remove the pulley (5128 & 5129), key (0436) and bearing (5025) from one end of the reel, then undo the nyloc nut (5089) and remove the rotor shaft washer (0039) from that end.
8. To undo one nyloc nut you will need to secure the nyloc nut at the other end.
9. Once the nut and rotor shaft washer have been removed you can remove blades (0232) and spacers (0972) from the shaft (0976).
10. Replace blades and spacers as required, ensuring that they go back on the shaft in the same direction and configuration (i.e counter rotating to direction of forward travel and successive blades offset one face on the rotor shaft).
11. Refit the rotor shaft washer and nyloc nut when blades are replaced and tighten nut back up.
12. Loosely re-fit the bearing (5025) on the end of the rotor shaft (0976)

- and re-position the reel under the Verticutter.
13. Securely bolt the blade reel in place.
 14. Tighten the bearing (5025) back onto the shaft (0976) and refit the lower pulley (5128), checking the alignment with the top pulley (5140) to keep the drive belts (5164) in line.
 15. Re-fit the and Re-tension the drive belts as per **6.1**
 16. Re-fit belt covers.

6.2.2 Belt Replacement

Note :Most of the stretch that belts experience takes place in the first few hours under load conditions after they have been first installed. After fitting new belts it is advisable that the tension be checked regularly in the first few hours of operation and re-tensioned as required.

Drive belts

1. Remove belt covers (0984 & 0985).
2. Slacken idler arm adjuster (0424) to remove all tension on the drive belts (5164).
3. Remove belts from the pulleys (5128 & 5140).
4. Fit new belts.
5. Adjust tension on the idler arm adjuster as per **6.1**
6. Re-fit belt covers.

6.3 Gearbox & P.T.O. Shaft

The gearbox (5134) should not require servicing. Annual checking of the oil level and oil quality should be all that is required. If topping up is required then use Gear Oil SAE 80W90.

The P.T.O. Shaft comes with its own set of instructions included with this manual. Follow all maintenance procedures as outlined in these instructions to maintain your P.T.O. Shaft in good condition.

6.4 Maintenance Schedule

IMPORTANT : Please read the separate instructions supplied with the PTO shaft for all maintenance intervals and procedures for the PTO shaft.

After first 4 hours :

- Check tension on drive belts ; adjust as per **6.1**
- Generally check for any loose nuts or fittings, especially blade reel retaining bolts

Daily : Before Use

- Check for worn, slipping or damaged belts
- Check for even tyre pressure (recommended 140 kPa ; 20 psi)
- Check for worn or damaged blades
- Check for any loose nuts, bolts and fasteners
- Ensure all guards are securely in place

Daily : After Use

- Clear rotor blades of any debris
- Clear any debris generally, especially from around PTO shaft and drive belts

Every 40 Hours

- Grease rotor shaft bearings (5025)
- Grease extension shaft and extension bar bearings (5132)

Every 6 Months

- Grease all bearings
- Grease uni-joint cross (5289)
- Check all belts for wear and tension ; replace if necessary

Every 12 Months

- Annual service should thoroughly check all of the above.
- Check oil level and quality in gearbox.
- Recommend changing all belts if this hasn't already been done, unless belts appear to be in good condition and will last another twelve months.

8. Parts & Illustrations

COVER DIAGRAM

Part Number	Description
0914	Right Hand Upright
0915	Left Hand Upright
0967	Offset Large Cover
0979	Left Hand Upper Cover Mount
0980	Upper Cover Mount
0981	Lower Cover Mount
0983	Crossbar
0984	Left Hand Belt Cover
0985	Right Hand Belt Cover
1005	Shroud
5067	¾" Heavy Duty External Circlip
5136	4.10 x 3.50 - 4 Slick Tyre
5137	4.10 x 3.50 Tube
5285	Bolt On Mounting Pin
5286	Alloy Rim
5291	PTO Shaft
9108	Wheel Spacer
A	½" UNF x ¾" Long Bolt
B	½" Internal Tooth Washer
C	¼" Flat Washer
D	5/16" UNF x ¾" Long Bolt
E	5/16" Internal Tooth Washer
F	5/16" Spring Washer
G	5/16" Flat Washer
H	5/16" Hex Nut
I	5/16" UNF x 2" Long Bolt
J	3/8" UNF x 1 ½" Long Bolt
K	3/8" Flat Washer
L	3/8" UNF Nyloc Nut
M	½" UNF x 1 ½" Long Bolt
N	½" Flat Washer
O	½" UNF Nyloc Nut
P	¾" Flat Washer
Q	7/8" Spring Washer
R	7/8" UNF Hex Nut
S	M8 x 25mm Long Bolt

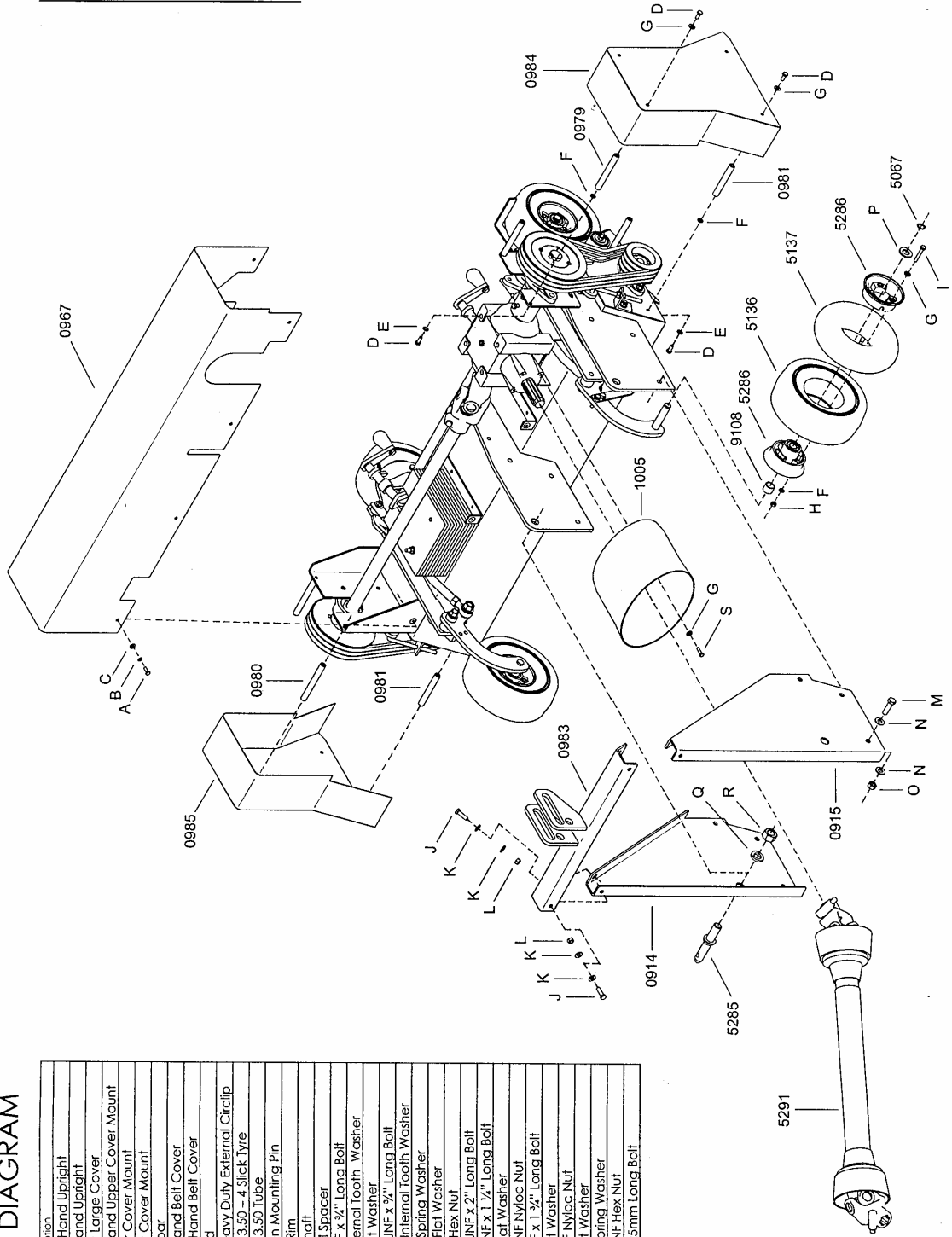

GEARBOX & WHEEL ARM DIAGRAM

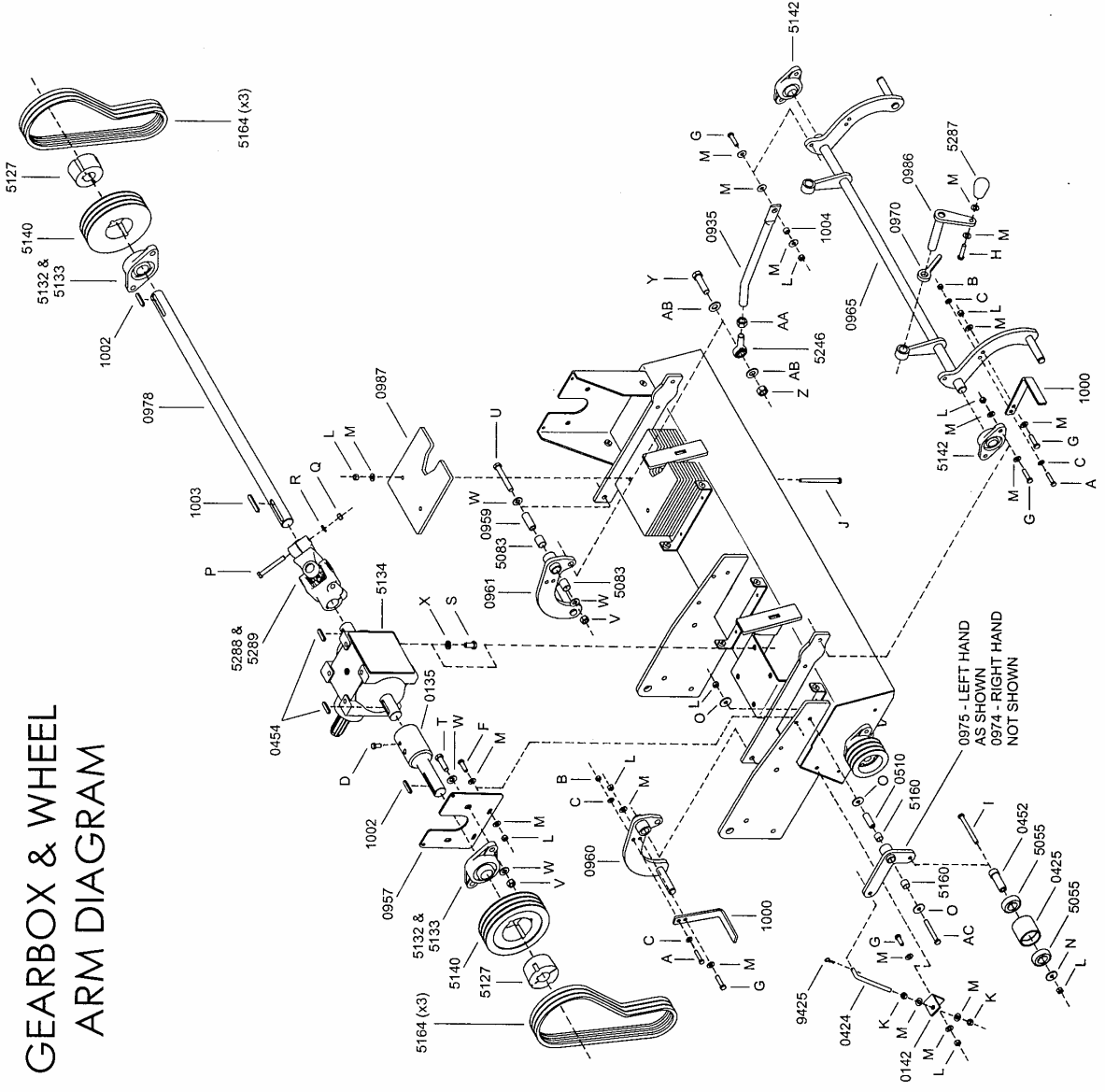

Part Number	Description
0135	Extension Shaft
0142	Idler Adjuster Bracket
0424	Idler Adjuster
0425	Idler Tube
0452	Side Idler Bush
0454	Key
0510	Bush
0935	Adjusting Bar
0937	Support Plate
0939	Idler Bush
0960	Left Hand Front Arm
0961	Right Hand Front Arm
0965	Trailing Arm Assembly
0970	Locking Lever
0974	Right Hand Idler Arm
0975	Left Hand Idler Arm
0978	Extension Bar
0986	Height Adjustment Screw
0987	Counterweight Plate
1000	Scrapers
1002	Key
1003	Key
1004	Bush
5065	Bearing
5083	Bronze Sintered Bush
5127	35mm Taper Lock Hub
5132	35mm Bearing
5133	35mm Bearing Housing
5134	Gearbox
5140	185mm x 3 Belf Pulley
5142	1" Bearing Assembly
5160	Bronze Sintered Bush
5164	Drive Bolt
5246	5/8" Rod End - Male
5287	Lever Knob
5288	35mm Clamping Yoke
5289	Uni-Joint Cross
9425	2mm R-Clip
A	5/16" N/loc Nut
B	5/16" Flat Washer
C	3/8" UNF x 3/4" Long Bolt
D	3/8" UNF x 1" Long Bolt
E	3/8" UNF x 1 1/2" Long Bolt
F	3/8" UNF x 1 1/2" Long Bolt
G	3/8" UNF x 1 1/2" Long Bolt
H	3/8" UNF x 1 1/2" Long Bolt
I	3/8" UNF x 4" Long Bolt
J	3/8" UNF x 5" Long Bolt
K	3/8" UNF Hex Nut
L	3/8" UNF Nyloc Nut
M	3/8" Flat Washer
N	3/8" High Tensile Washer
O	3/8" x 1 1/2" Guard Washer
P	M10 x 80mm Long Bolt
Q	M10 Hex Nut
R	M10 Spring Washer
S	M12 x 25mm Long Bolt
T	1/2" UNF x 1 3/4" Long Bolt
U	1/2" UNF x 3 1/2" Long Bolt
V	1/2" UNF Nyloc Nut
W	1/2" Flat Washer
X	1/2" Spring Washer
Y	5/8" UNF x 2 1/2" Long Bolt
Z	5/8" UNF Nyloc Nut
AA	5/8" Flat Washer
AB	5/8" Flat Washer
AC	3/8" UNF x 3" Long Bolt

BLADE DIAGRAM

Part Number	Description
0039	Rotor Shaft Washer
0217	3mm Blade
0232	2mm Blade
0436	Key
0971	Spacer - 40mm
0972	Spacer - 30mm
0976	Rotor Shaft
0982	Offset Base Assembly
5025	7/8" Bearing & Housing Unit
5089	1"UNF x 12 T.P.I. Nyloc Nut
5128	100mm x 3 Belt Pulley
5129	7/8" Taper Lock Hub
5164	Drive Belt
A	3/8"UNF x 1 1/4" Long Bolt
B	3/8" Flat Washer
C	3/8"UNF Nyloc Nut

STANDARD SETUP SHOWN 39 x 2mm blades (0232) with 30mm spacers (0972)

Other reel configurations available:
 39 x 3mm blades (0217) with 30mm spacers (0972)
 30 x 2mm blades (0232) with 40mm spacers (0971)
 30 x 3mm blades (0217) with 40mm spacers (0971)

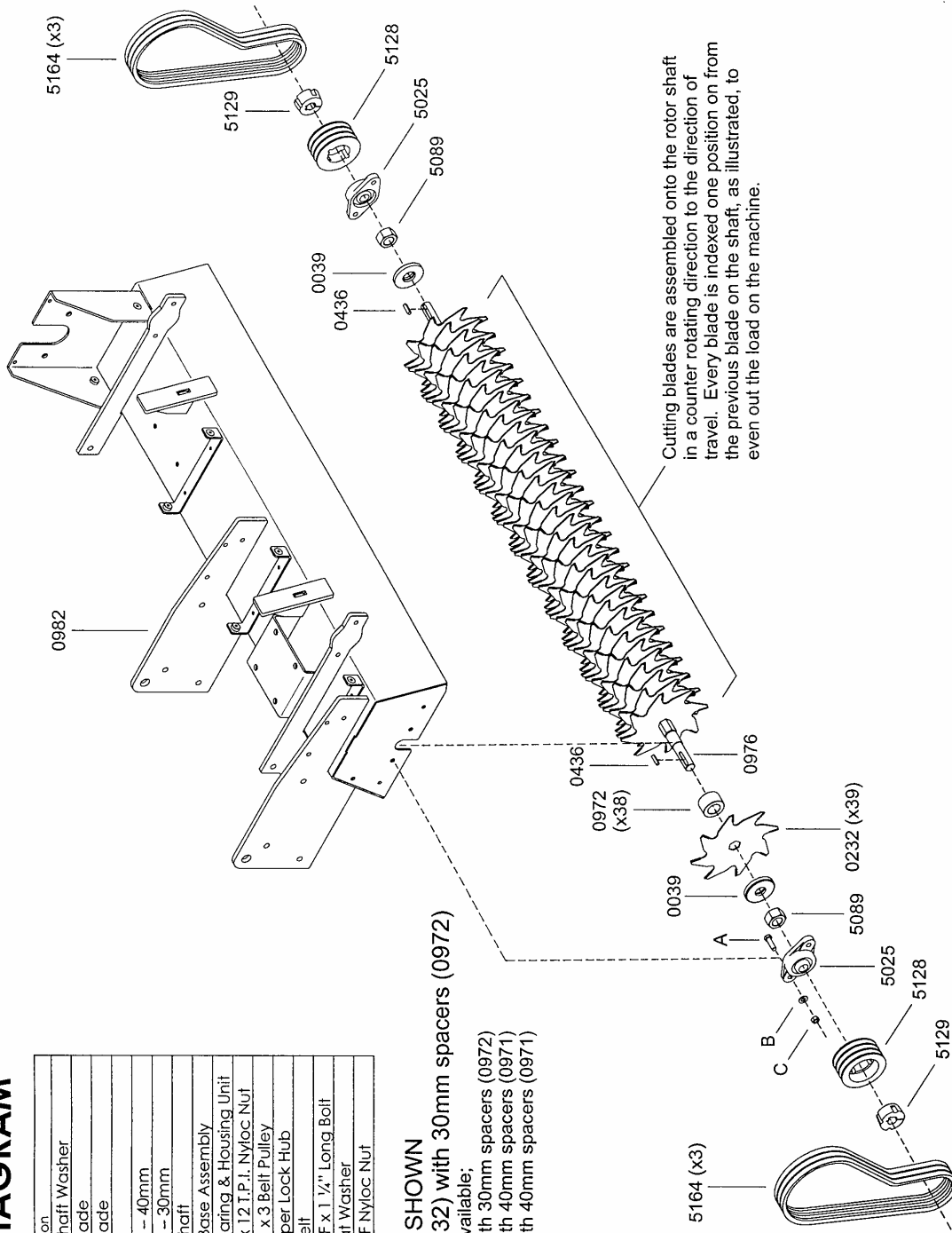

8.2 Warning/Compliance Decals



PART NO. 5290 – Cover Warning Decal (x5)



PART NO. 5154 – Danger Decal (x6)



PART NO. 5179 - CE Decal (x1)

GRADEN TURF MACHINERY

Manufactured under licence by

Turf Machinery

1 Waitchie Street

Wedderburn 3518

Victoria Australia

Tel - (03) 5494 3059

Web - gradenturfmachinery.com

Email - turf.engineering@bigpond.com

Contact - Geoff Burnside © 2003 - 2004 Turf Machinery